

# JVC

# SERVICE MANUAL

## COMPACT COMPONENT SYSTEM

### MX-K5 / MX-K6

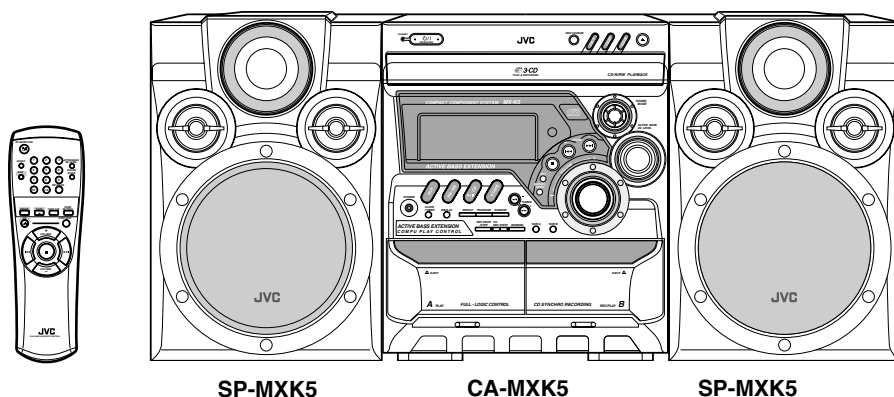

**MX-K5**

**Area Suffix**

J ..... U.S.A.  
C ..... Canada

**MX-K6**

**Area Suffix**

C ..... Canada



SP-MXK5

CA-MXK5

SP-MXK5

**Each difference points**

MODEL	CD/DECK/ RECEIVER	Speaker	Color		
			POWER / SUB / CD EJECT / DISK CHANGER bottom	VOLUME RING ornament	CD fitting
MX-K5	CA-MXK5	SP-MXK5	SILVER	←	←
MX-K6	CA-MXK6	SP-MXK6	METALLIC LIGHT GRAY	←	←

**Contents**

Safety Precautions .....	1-2	Flow of functional operating	
Important for laser products .....	1-3	until TOC read .....	1-24
Preventing static electricity .....	1-4	Maintenance of laser pickup .....	1-25
Disassembly method .....	1-5	Replacement of laser pickup.....	1-25
Wiring connection .....	1-19	Trouble shooting .....	1-26
Adjustment method .....	1-20	Description of major ICs .....	1-29

## Safety Precautions

1. This design of this product contains special hardware and many circuits and components specially for safety purposes. For continued protection, no changes should be made to the original design unless authorized in writing by the manufacturer. Replacement parts must be identical to those used in the original circuits. Services should be performed by qualified personnel only.
2. Alterations of the design or circuitry of the product should not be made. Any design alterations of the product should not be made. Any design alterations or additions will void the manufacturer's warranty and will further relieve the manufacture of responsibility for personal injury or property damage resulting therefrom.
3. Many electrical and mechanical parts in the products have special safety-related characteristics. These characteristics are often not evident from visual inspection nor can the protection afforded by them necessarily be obtained by using replacement components rated for higher voltage, wattage, etc. Replacement parts which have these special safety characteristics are identified in the Parts List of Service Manual. Electrical components having such features are identified by shading on the schematics and by ( $\triangle$ ) on the Parts List in the Service Manual. The use of a substitute replacement which does not have the same safety characteristics as the recommended replacement parts shown in the Parts List of Service Manual may create shock, fire, or other hazards.
4. The leads in the products are routed and dressed with ties, clamps, tubings, barriers and the like to be separated from live parts, high temperature parts, moving parts and/or sharp edges for the prevention of electric shock and fire hazard. When service is required, the original lead routing and dress should be observed, and it should be confirmed that they have been returned to normal, after re-assembling.
5. Leakage current check (Electrical shock hazard testing)  
After re-assembling the product, always perform an isolation check on the exposed metal parts of the product (antenna terminals, knobs, metal cabinet, screw heads, headphone jack, control shafts, etc.) to be sure the product is safe to operate without danger of electrical shock. Do not use a line isolation transformer during this check.

- Plug the AC line cord directly into the AC outlet. Using a "Leakage Current Tester", measure the leakage current from each exposed metal parts of the cabinet, particularly any exposed metal part having a return path to the chassis, to a known good earth ground. Any leakage current must not exceed 0.5mA AC (r.m.s.)

- Alternate check method

Plug the AC line cord directly into the AC outlet. Use an AC voltmeter having, 1,000 ohms per volt or more sensitivity in the following manner. Connect a 1,500 $\Omega$  10W resistor paralleled by a 0.15  $\mu$ F AC-type capacitor between an exposed metal part and a known good earth ground.

Measure the AC voltage across the resistor with the AC voltmeter.

Move the resistor connection to each exposed metal part, particularly any exposed metal part having a return path to the chassis, and measure the AC voltage across the resistor. Now, reverse the plug in the AC outlet and repeat each measurement. voltage measured any must not exceed 0.75 V AC (r.m.s.). This corresponds to 0.5 mA AC (r.m.s.).

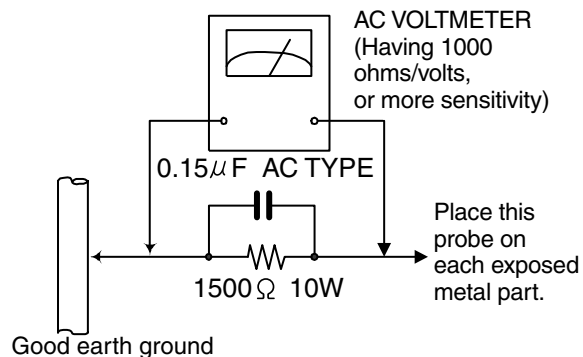

## Warning

1. This equipment has been designed and manufactured to meet international safety standards.
2. It is the legal responsibility of the repairer to ensure that these safety standards are maintained.
3. Repairs must be made in accordance with the relevant safety standards.
4. It is essential that safety critical components are replaced by approved parts.
5. If mains voltage selector is provided, check setting for local voltage.

**CAUTION** Burrs formed during molding may be left over on some parts of the chassis. Therefore, pay attention to such burrs in the case of preforming repair of this system.

# Important for laser products

## 1.CLASS 1 LASER PRODUCT

**2.DANGER** : Invisible laser radiation when open and interlock failed or defeated. Avoid direct exposure to beam.

**3.CAUTION** : There are no serviceable parts inside the Laser Unit. Do not disassemble the Laser Unit. Replace the complete Laser Unit if it malfunctions.

**4.CAUTION** : The compact disc player uses invisible laserradiation and is equipped with safety switches which prevent emission of radiation when the drawer is open and the safety interlocks have failed or are defeated. It is dangerous to defeat the safety switches.

**5.CAUTION** : If safety switches malfunction, the laser is able to function.

**6.CAUTION** : Use of controls, adjustments or performance of procedures other than those specified herein may result in hazardous radiation exposure.

**CAUTION** Please use enough caution not to see the beam directly or touch it in case of an adjustment or operation check.

## REPRODUCTION AND POSITION OF LABELS

### WARNING LABEL

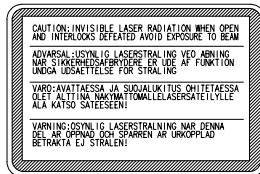

## FUSE CAUTION

### FUSE CAUTION LABEL

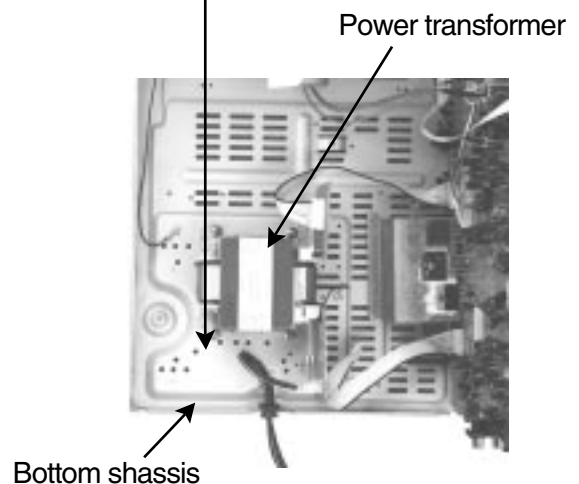
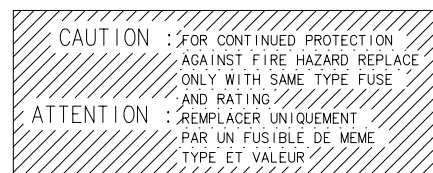

## Preventing static electricity

### 1. Grounding to prevent damage by static electricity

Electrostatic discharge (ESD), which occurs when static electricity stored in the body, fabric, etc. is discharged, can destroy the laser diode in the traverse unit (optical pickup). Take care to prevent this when performing repairs.

### 2. About the earth processing for the destruction prevention by static electricity

In the equipment which uses optical pick-up (laser diode), optical pick-up is destroyed by the static electricity of the work environment.

Be careful to use proper grounding in the area where repairs are being performed.

#### 2-1 Ground the workbench

Ground the workbench by laying conductive material (such as a conductive sheet) or an iron plate over it before placing the traverse unit (optical pickup) on it.

#### 2-2 Ground yourself

Use an anti-static wrist strap to release any static electricity built up in your body.

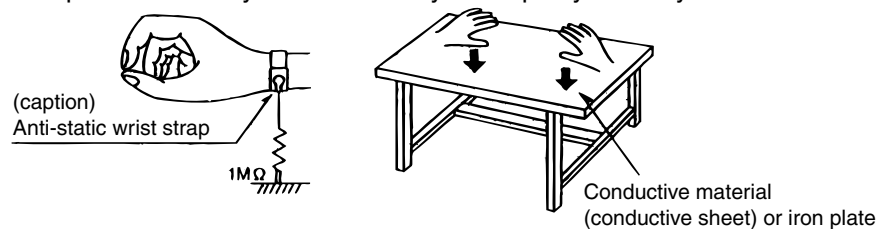

### 3. Handling the optical pickup

1. In order to maintain quality during transport and before installation, both sides of the laser diode on the replacement optical pickup are shorted. After replacement, return the shorted parts to their original condition. (Refer to the text.)

2. Do not use a tester to check the condition of the laser diode in the optical pickup. The tester's internal power source can easily destroy the laser diode.

### 4. Handling the traverse unit (optical pickup)

1. Do not subject the traverse unit (optical pickup) to strong shocks, as it is a sensitive, complex unit.

2. Cut off the shorted part of the flexible cable using nippers, etc. after replacing the optical pickup. For specific details, refer to the replacement procedure in the text. Remove the anti-static pin when replacing the traverse unit. Be careful not to take too long a time when attaching it to the connector.

3. Handle the flexible cable carefully as it may break when subjected to strong force.

4. It is not possible to adjust the semi-fixed resistor that adjusts the laser power. Do not turn it

### Attention when CD mechanism assembly is decomposed

**\*Please refer to "Disassembly method" in the text for pick-up and how to detach the CD mechanism assembly.**

1. Remove the CD changer unit.

2. Remove the CD changer mechanism.

3. Solder is put up before the card wire is removed from the pickup unit connector on the CD mechanism assembly.

(When the card wire is removed without putting up solder, the CD pick-up assembly might destroy.)

4. Please remove solder after connecting the card wire with the pickup unit connector when you install picking up in the substrate.

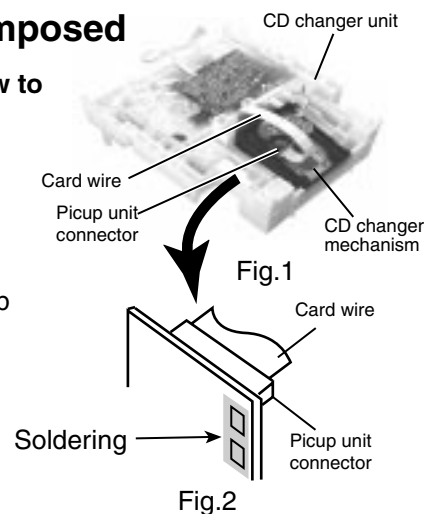

# Disassembly method

## <Main body>

### ■ Removing the metal cover

(See Fig.1 to 3)

1. Remove the three screws **A** attaching the metal cover on the back of the body.
2. Remove the six screws **B** attaching the metal cover on both sides of the body.
3. Remove the metal cover from the body by lifting the rear part of the cover.

ATTENTION: Do not break the front panel tab fitted to the metal cover.

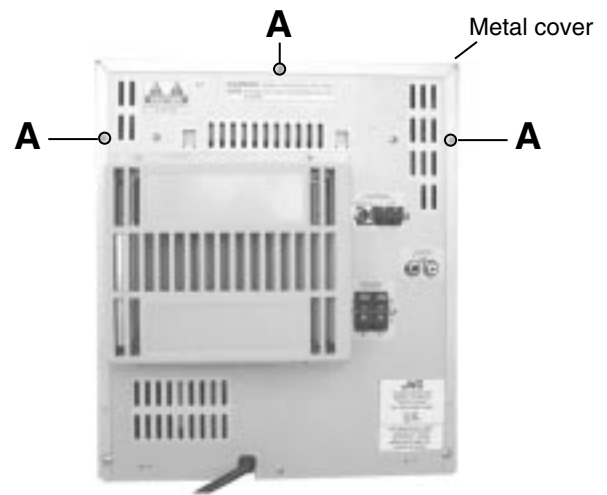

Fig.1

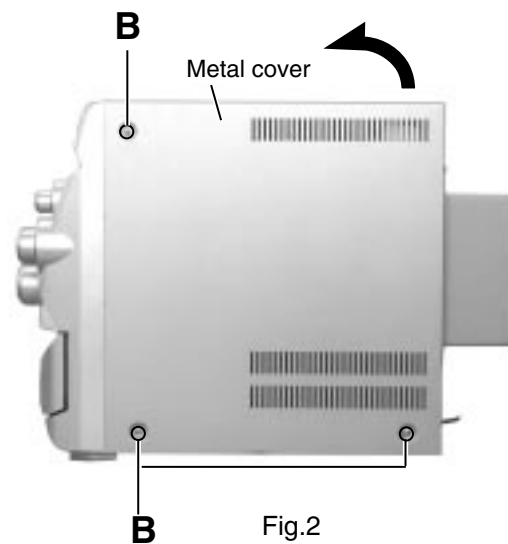

Fig.2

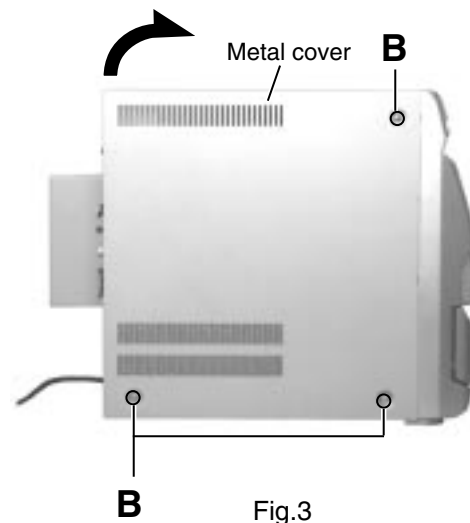
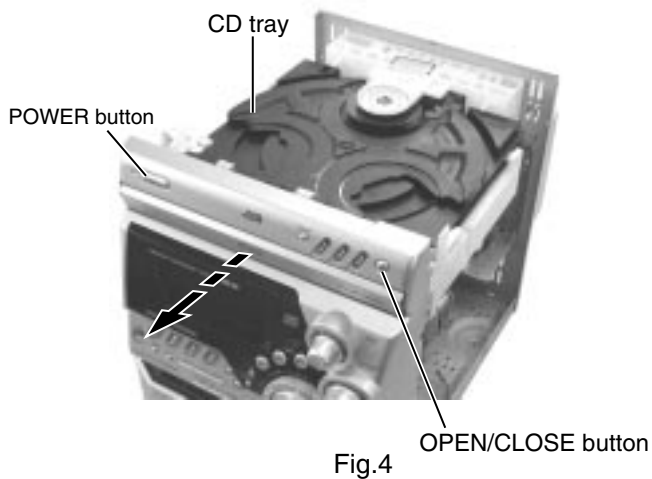

Fig.3

**■Removing the CD Tray fitting (1)**  
(See Fig. 4 to 6)

- Prior to performing the following procedure, remove the metal cover.
- 1. Press the POWER button. Press the OPEN/CLOSE button to eject the CD tray.
- 2. After drawing the lower part of the tray fitting toward the front, remove the five claws **a**. Then, while moving the tray fitting upward, remove it.
- 3. Press the OPEN/CLOSE button to insert the tray.



**■Removing the CD Tray fitting (2)**  
(See Fig. 5 to 7)

**- How to eject the CD tray without turning on power -**

1. Turn the black loading pulley gear marked **b** from the back of the CD changer unit as shown in Fig.7 and draw the CD tray toward the front.
2. After drawing the lower part of the tray fitting toward the front, remove the five claws **a**. Then, while moving the tray fitting upward, remove it.
3. Push and insert the CD tray manually.

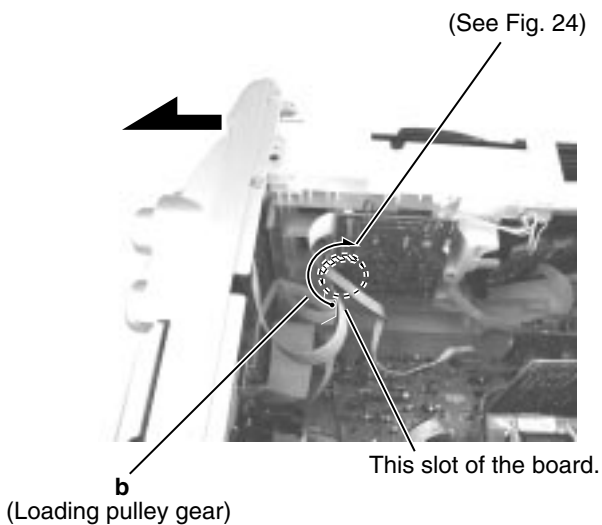
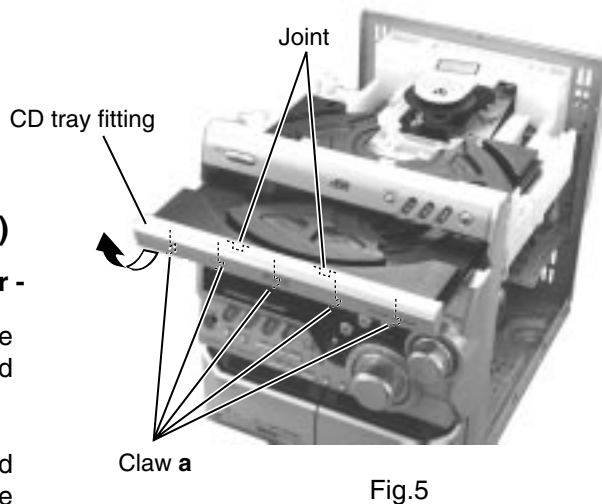

Fig.7

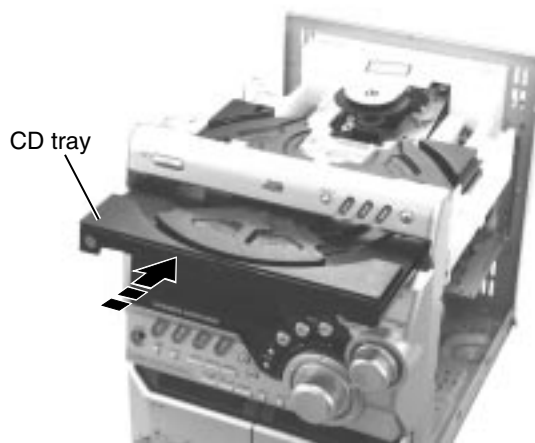

Fig.6

## ■ Removing the CD changer unit (See Fig.8 to 10)

• Prior to performing the following procedure, remove the metal cover.

1. Disconnect the card wire which is attached with adhesive to the left side of the CD changer unit.
2. Disconnect the card wire from connector CW105 of the CD servo board on the back of the CD changer unit.
3. Disconnect the harness from connector RCW6 on the inner side of the main board in the body.

Remove the two screws **C** attaching the CD changer unit on the back of the body.

Remove the two screws **D** attaching the CD changer unit on the both side of the body.

Draw the CD changer unit upward from behind while pulling the rear panel outward.

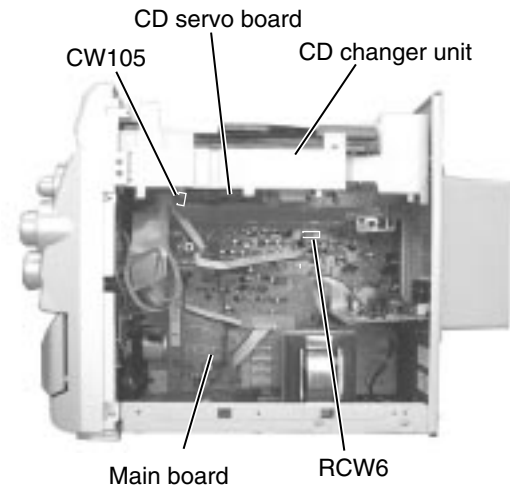

Fig.8

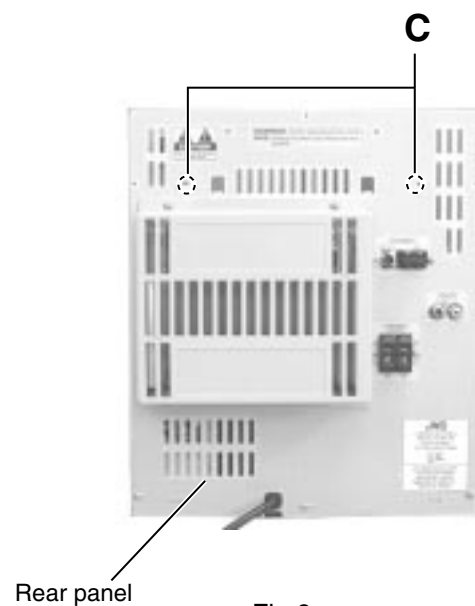

Fig.9

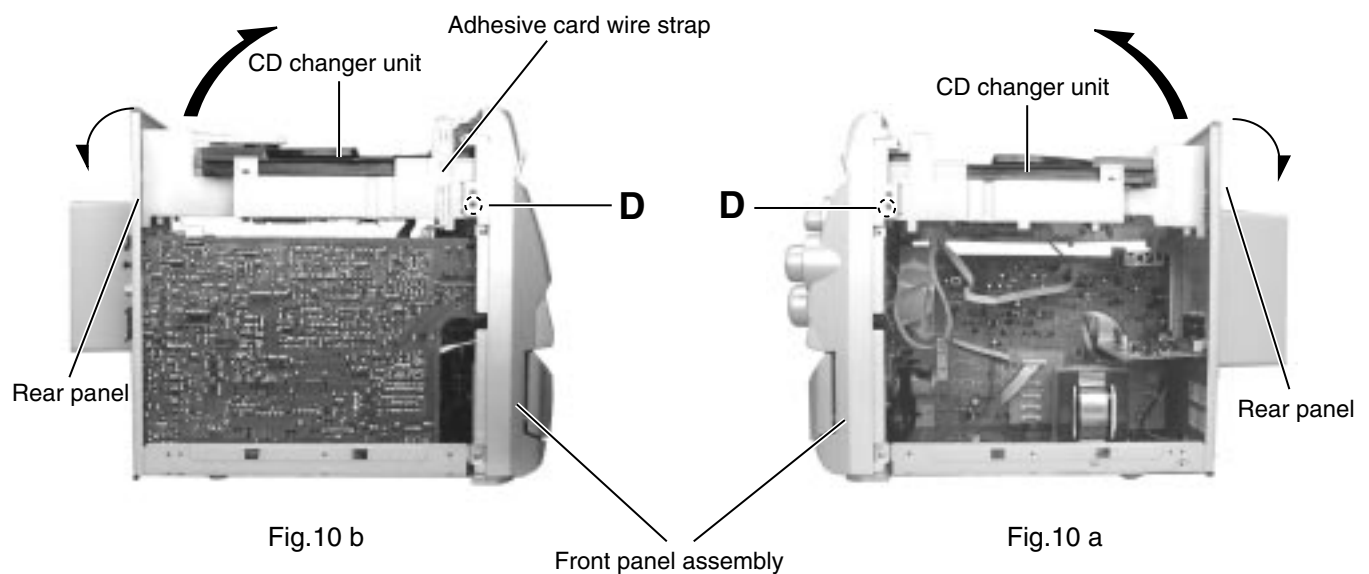
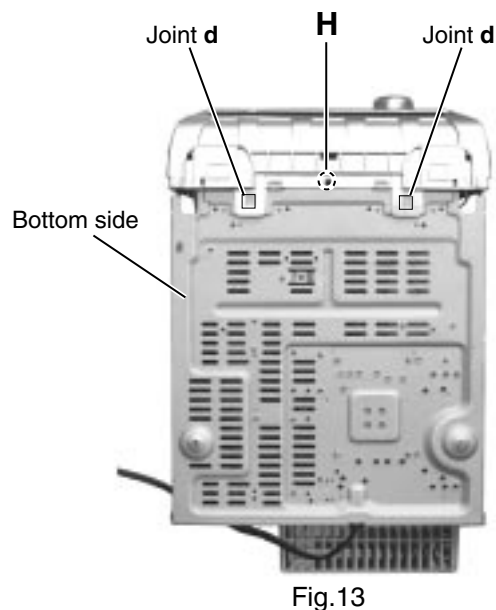
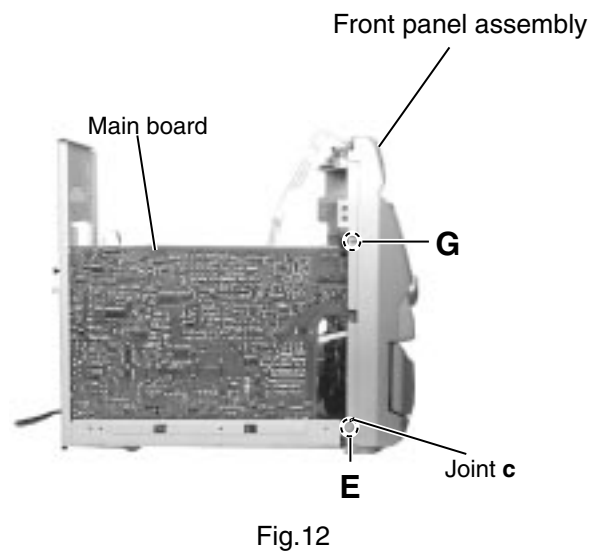
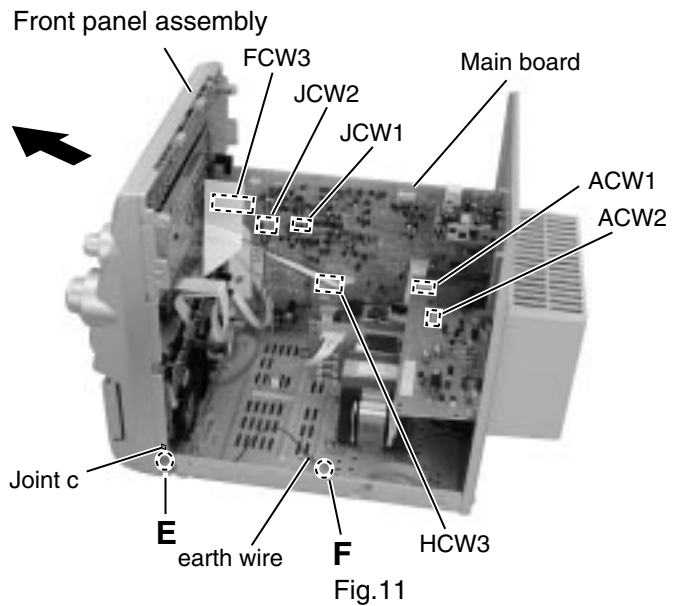

Fig.10 b

Fig.10 a

**■Removing the front panel assembly  
(See Fig.11 to 13)**

- Prior to performing the following procedure, remove the metal cover and the CD changer unit.
1. Disconnect the card wire from connector FCW3 and the harness from connector JCW1, JCW2 and HCW3 on the inner side of the main board in the body.
  2. Remove the two screws **E** attaching the front panel assembly on both sides of the body.
  3. Remove the screw **F** attaching the earth terminal extending from the cassette mechanism assembly.
  4. Remove the screw **G** attaching the front panel assembly and main board.
  5. Remove the screw **H** attaching the front panel assembly on the bottom of the body.
  6. Release the two joints **c** on both sides and two joints **d** on the bottom of the body using a screwdriver.





## ■ Removing the heat sink & AMP board (See Fig.14 and 15)

- Prior to performing the following procedure, remove the metal cover and the CD changer unit.
1. Remove the four screws **I** attaching the heat sink cover on the back of the body. Remove the heat sink cover.
  2. Remove the four screws **J** attaching the heat sink & AMP board to the rear panel on the back of the body.
  3. Remove the two screws **K** attaching the speaker terminal to the rear panel on the back of the body.
  4. Disconnect the card wire from connector ACW1 & the harness from connector ACW2 on the AMP board. (See Fig.11)
  5. After moving the heat sink upward, remove the claws. Then pull out the heat sink & AMP board

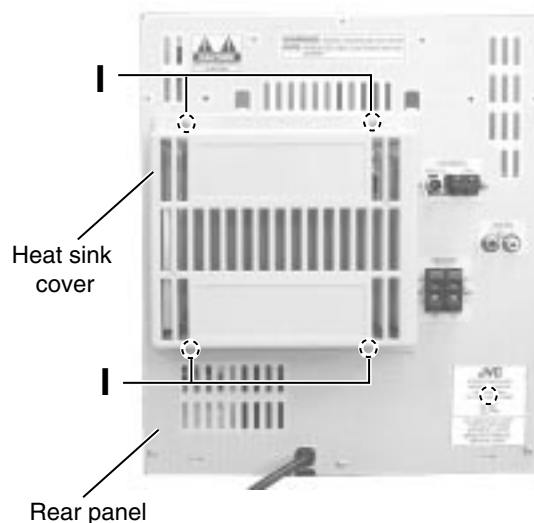

Fig.14

## ■ Removing the tuner pack (See Fig.15 and 16)

- Prior to performing the following procedure, remove the metal cover and CD changer unit.
1. Disconnect the card wire from connector CON01 on the tuner board.
  2. Remove the two screws **L** attaching the tuner pack.

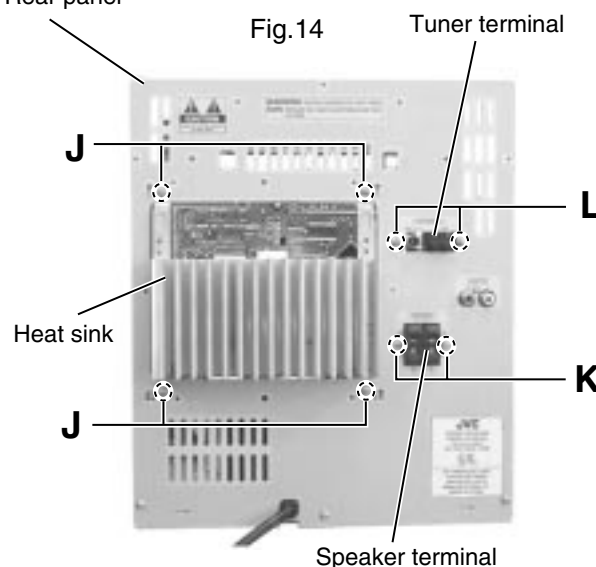

Fig.15

## ■ Removing the rear cover (See Fig.17)

- Prior to performing the following procedure, remove the metal cover, CD changer unit, heat sink & AMP board and tuner pack.
1. Remove the four screws **M** attaching the rear panel.

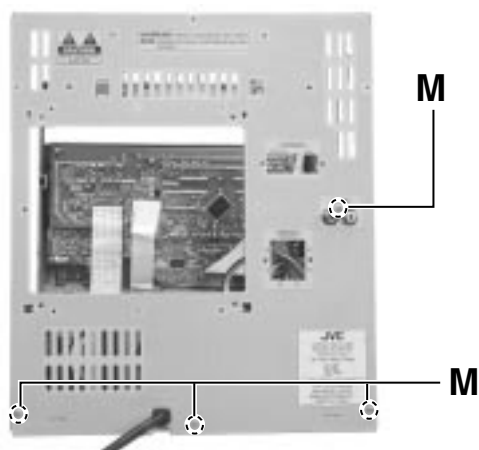

Fig.17

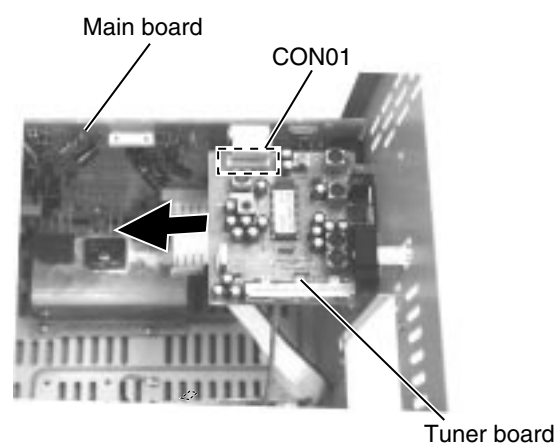

Fig.16

### ■Removing the main Board

(See Fig. 18)

- Prior to performing the following procedure, remove the metal cover, CD changer unit.
1. Disconnect the card wire from connector FCW3 and the harness from connector JCW1, JCW2 and HCW3 on the main board.
  2. Disconnect the harness from connector PCW1 on the power transformer board.
  3. Remove the screw **G** attaching the main board holder. (See Fig.12)
  4. Remove the two screws **N** attaching the heat sink and bottom chassis.

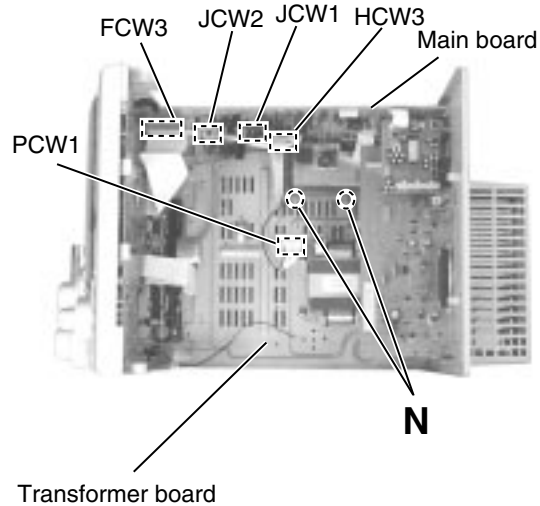

Fig.18

### ■Removing the power IC

(See Fig.19 and 20)

- Prior to performing the following procedure, remove the metal cover CD changer unit and heat sink & AMP board.
1. Remove the two screws **P** attaching the power IC to the heat sink.
  2. Unsolder the power IC solder point.

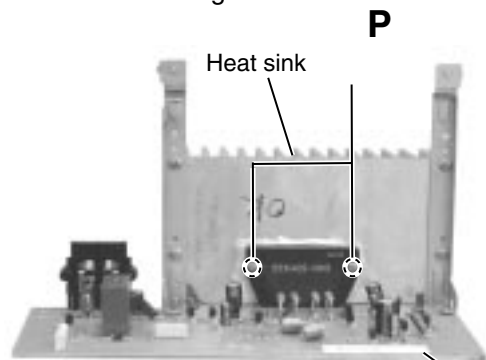

Fig.19

### ■Removing the power transformer

(See Fig .21)

- Prior to performing the following procedure, remove the metal cover, heat sink & AMP board, tuner pack and rear cover.
1. Disconnect the power cord from connector RCW2 of the power transformer board.
  2. Disconnect the harness from connector PCW1 of the power transformer board.
  3. Remove the four screws **R** attaching the power transformer and the screw **S** attaching the earth.

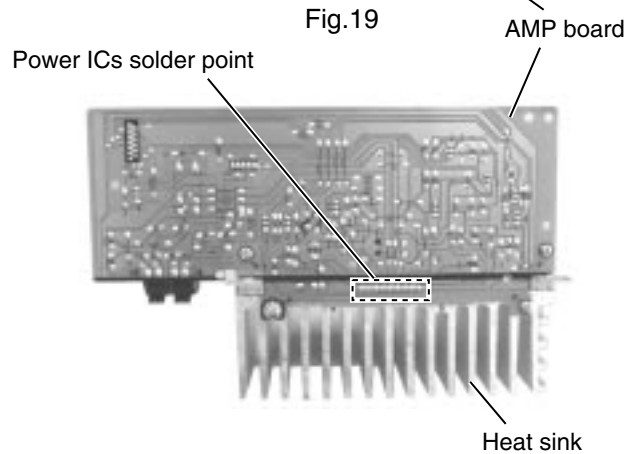

Fig.20

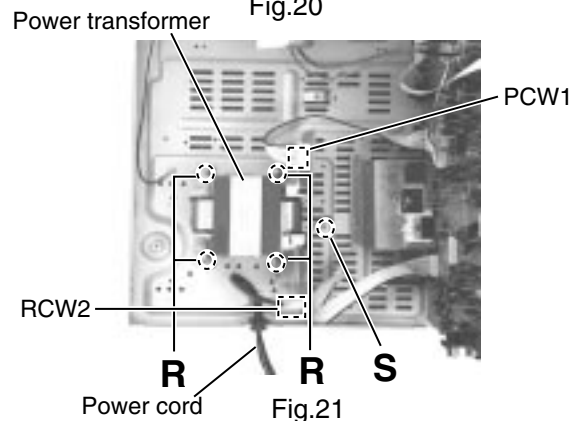

Fig.21

## <Front panel assembly>

- Prior to performing the following procedure, remove the metal cover, the CD changer unit and the front panel assembly.

### ■ Removing the power / CD switch board (See Fig.22)

1. Disconnect the card wire from connector UCW1 on the power / CD switch board.
2. Remove the five screws **T** attaching the power / CD switch board and release the tab **e**.

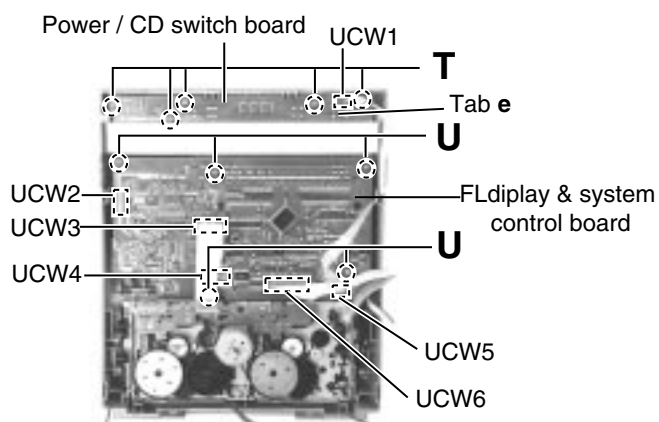

Fig.22

### ■ Removing the FL display & system control board (See Fig.22 and 23)

1. Disconnect the card wire from the connector UCW3, UCW4, UCW5 and UCW6 on the FL & system control board.
2. Remove the five screws **U** attaching the FL & system board.
3. Disconnect the card wire from the connector UCW2 on the FL & system control board.

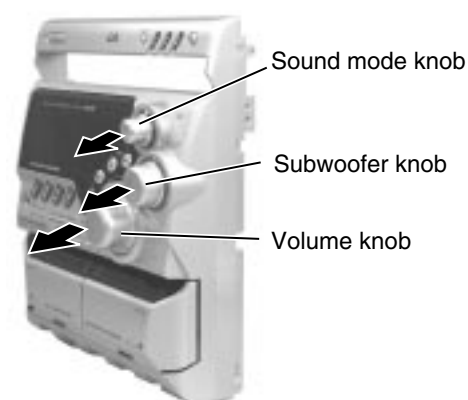

Fig.23

### ■ Removing the headphone board (See Fig.24)

- Prior to performing the following procedure remove the FLdisplay & system control board.

1. You can pull out the headphone board.

### ■ Removing the front board (See Fig.24)

- Prior to performing the following procedure, remove the FLdisplay & system control board.

1. Pull out the VOLUME knob, ACTIVE BASS EX. LEVEL knob and SOUND MODE nob from front side.
2. Remove the ten screws **V** attaching the front board and release the two tabs **f** out ward.

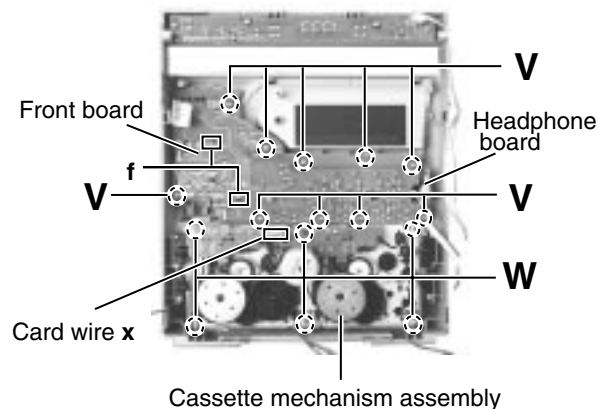

Fig.24

### ■ Removing the cassette mechanism assembly (See Fig.24)

1. Disconnect the card wire **x** from the mechanism board on the cassette mechanism assembly.
2. Remove the six screws **W** attaching the cassette mechanism assembly.

<CD changer unit>

- Prior to performing the following procedure, remove the CD changer unit.

■Removing the CD tray (See Fig.25 to 27)

1. Turn the black loading pulley gear on the under side of the CD changer unit in the direction of the arrow and draw the CD tray toward the front until it stops.
2. Disconnect the card wire from connector CW103 of the CD servo board on the upper side of the CD changer unit.
3. Push down the two tray stoppers marked **g** and pull out the CD tray.

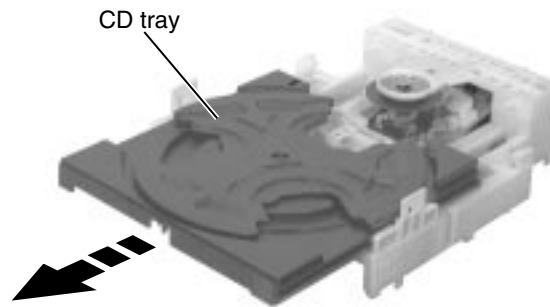
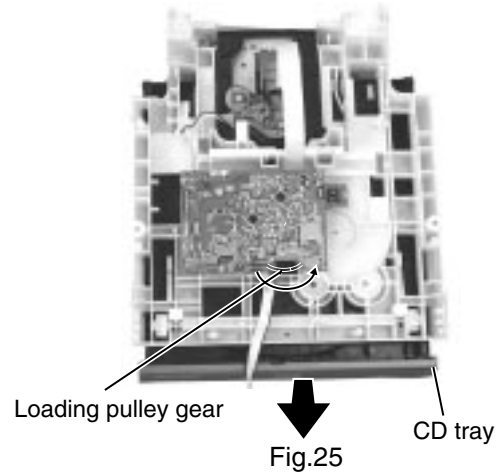

■Reinstall the CD tray (See Fig.28 to 29)

1. Align the gear-cam with the gear-tray as shown fig.27, then mount the CD tray.
2. When assembling the CD tray, take extreme care not engage with gear - synchro.

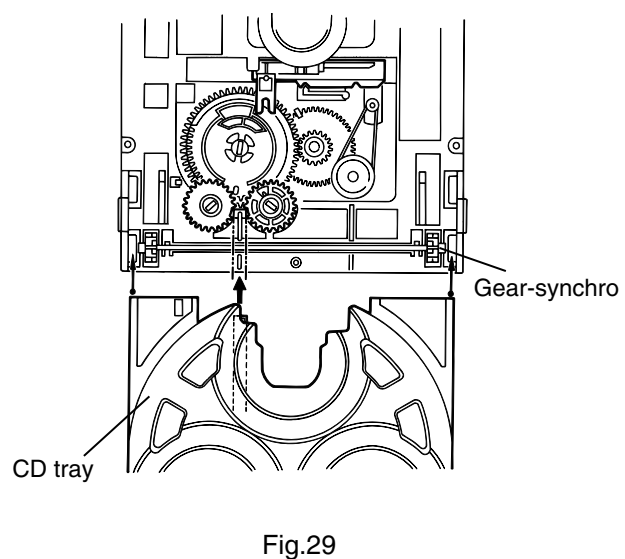
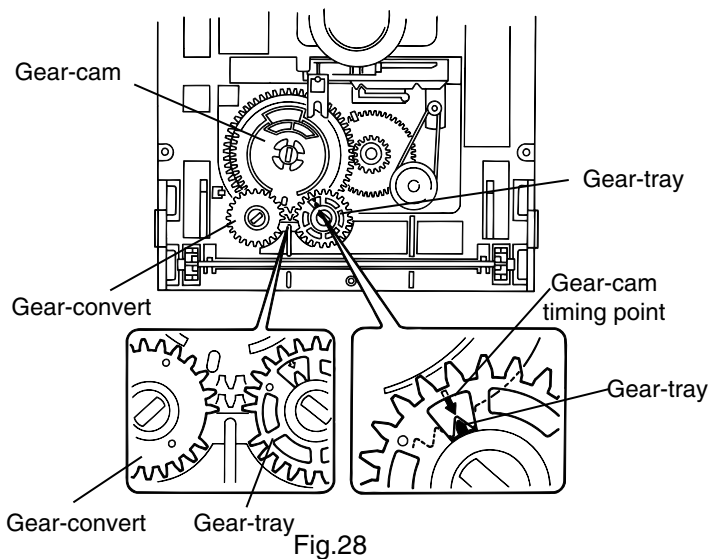
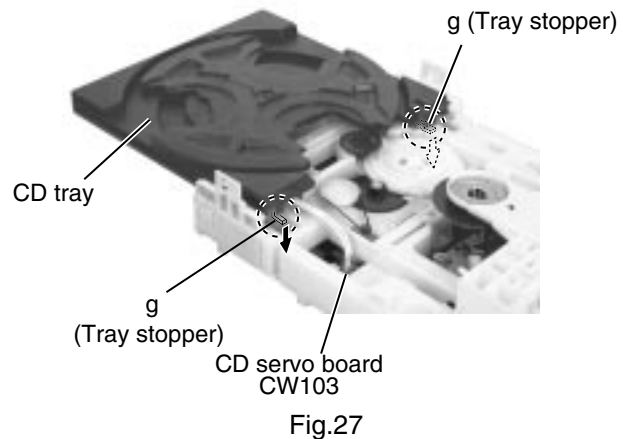

## ■ Removing the sensor board / the turn table motor assembly (See Fig.30 to 32)

• Prior to performing the following procedure, remove the CD tray.

1. Remove the screw **X** attaching the sensor board and release the two tabs **h** attaching the sensor board on the under side of the CD tray.
2. Disconnect the harness from connector **CW1** on the sensor board and release the harness from the two hooks **i**. Remove the sensor board.
3. Remove the screw **Y** attaching the turn table. Detach the turn table from the tray.
4. Pull outward the tab marked **j** attaching the turn table motor assembly on the upper side of the tray and detach the turn table motor assembly from the tray.

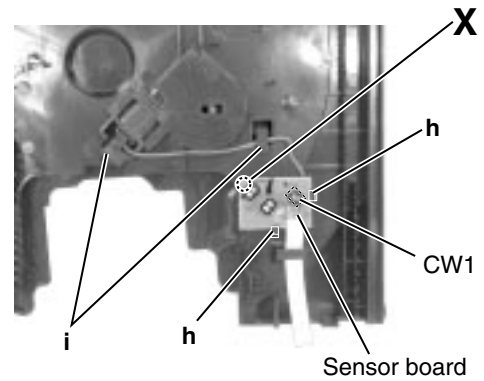

Fig.30

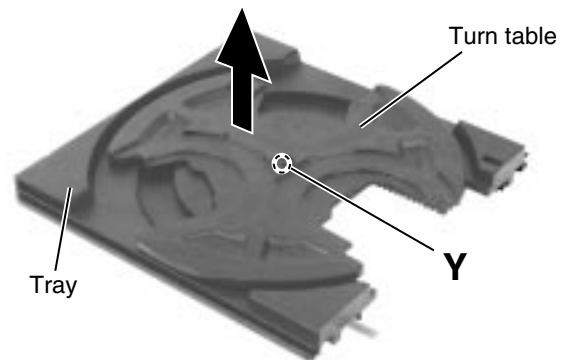

Fig.31

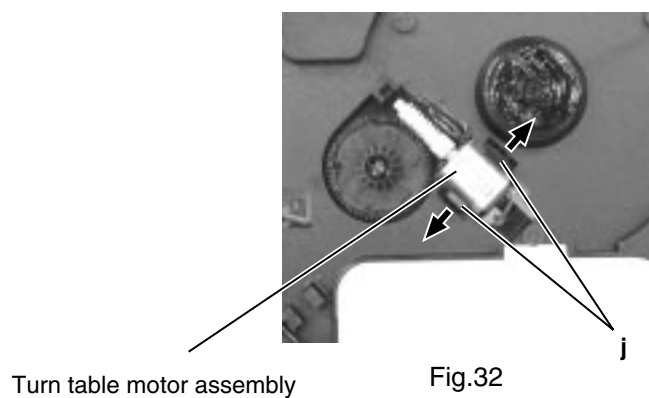

Fig.32

**■Removing the belt, the CD servo board and the switch board (See Fig.33 and 34)**

• Prior to performing the following procedure, remove the CD tray.

1. Detach the belt from the pulley on the upper side of the CD changer unit (Do not stain the belt with grease).
2. Disconnect the card wire from the pickup unit connector on the under side of the CD changer unit.

**Attention :** Solder is put up before the card wire is removed from the pick-up unit connector on the CD mechanism assembly.  
(When the card wire is removed without putting up solder, the CD pick-up unit assembly might destroy.)

3. Disconnect the motor wire harness from connector on the CD servo board.
4. Remove the screw **Z** attaching the switch board and release the two tabs **k** attaching the switch board outward and detach the switch board.
5. Remove the two screws **A'** attaching the CD servo board and . First release the **n** side of the two tabs **l** and two tabs **m** attaching the CD servo board motor to raise the CD servo board slightly, then release the CD servo board.

※If the tabs **l** and **m** are hard to release, it is recommendable to unsolder the two soldered parts on the motor terminal of the CD servo board.

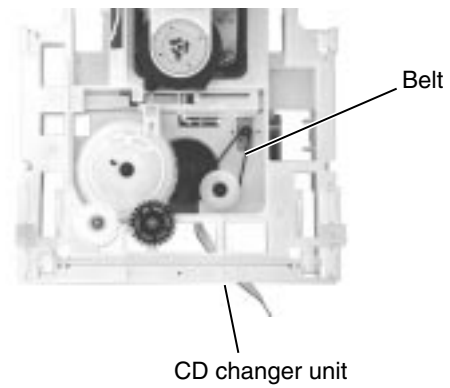

Fig.33

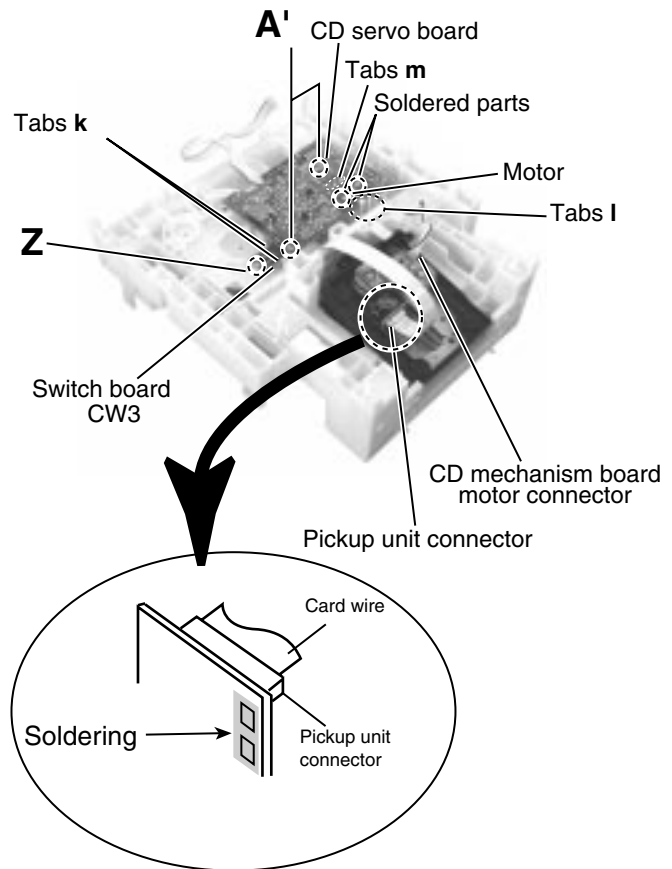

Fig.34

## ■ Removing the CD mechanism holder assembly (mechanism included) (See Fig.35 to 38)

1. Disconnect the harness from connector on the CD mechanism board in the CD mechanism assembly on the under side of the CD changer unit. Disconnect the card wire from the pickup unit connector.

**Attention :** Solder is put up before the card wire is removed from the pick-up unit connector on the CD mechanism assembly. (Refer to Fig. 33)  
(When the card wire is removed without putting up solder, the CD pick-up unit assembly might destroy.)

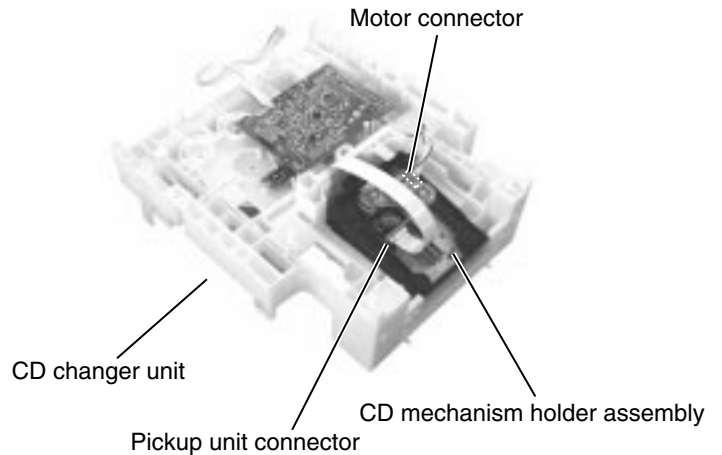

Fig.35

2. Remove the screw **B'** attaching the shaft on the right side of the CD mechanism holder assembly. Pull outward the stopper fixing the shaft on the left side and remove the CD mechanism holder assembly from behind in the direction of the arrow.
3. Turn the CD mechanism holder assembly half around the lift up slide shaft **n** of the CD mechanism holder assembly until the turn table is reversed, and pull out the CD mechanism holder assembly.

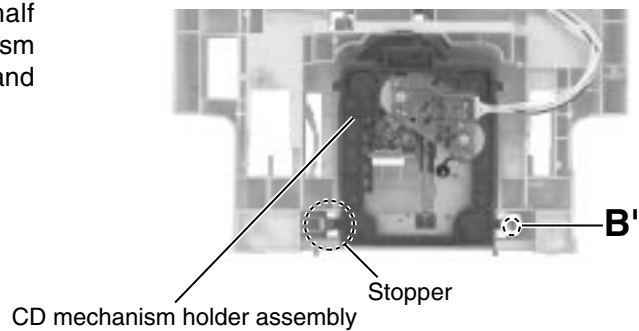

Fig.36

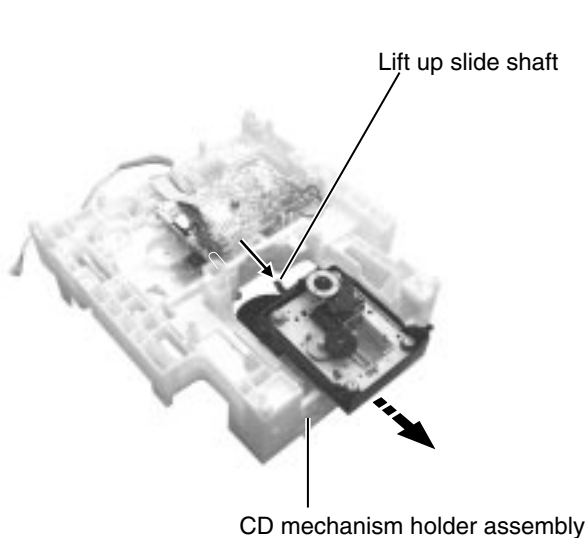

Fig.38

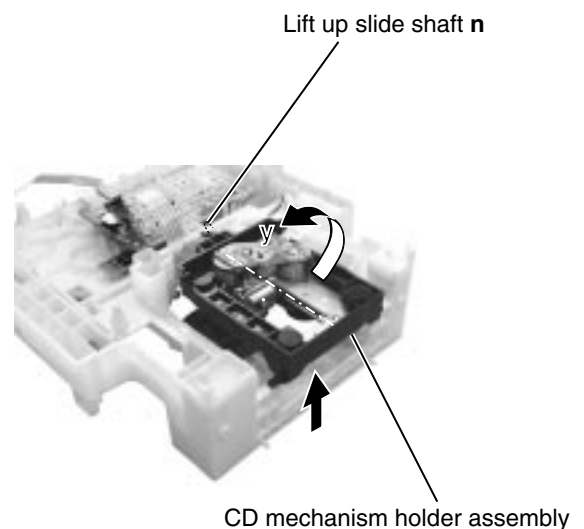

Fig.37

**<CD mechanism section>**

- Removing the CD mechanism holder from the CD chager unit.  
(Refer to "Removing the CD mechanism holder assembly" )

**■ Removing the pickup unit. (See Fig.1)**

1. Removing the cut washer **c** on the feed gear sleeve and pull out the feed gear.
2. Remove the two screws **A** fixing the pickup shaft.
3. Removing the pickup unit.

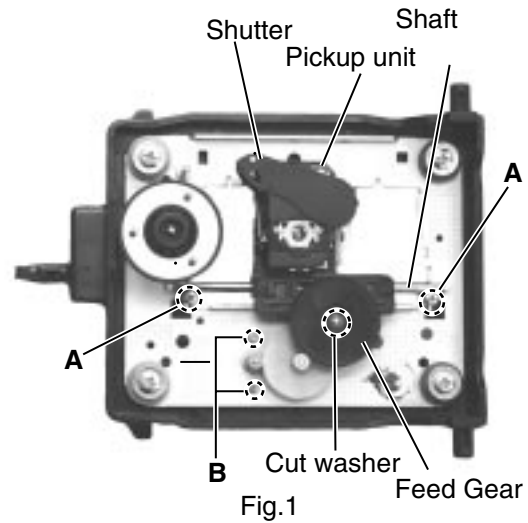

**■ Removing the motor board. (See Fig.2)**

1. Unsolder the motor terminal on the motor board.
2. Remove the moter board.

**■ Removing the feed motor. (See Fig.1)**

Remove the two motor fixing screws at **B** and removing the feed motor.

**■ Removing the spindle motor.**

The spindle motor cannot be removed as a single unit. When removing the spindle motor, change the chasis and turntable together as aunit.

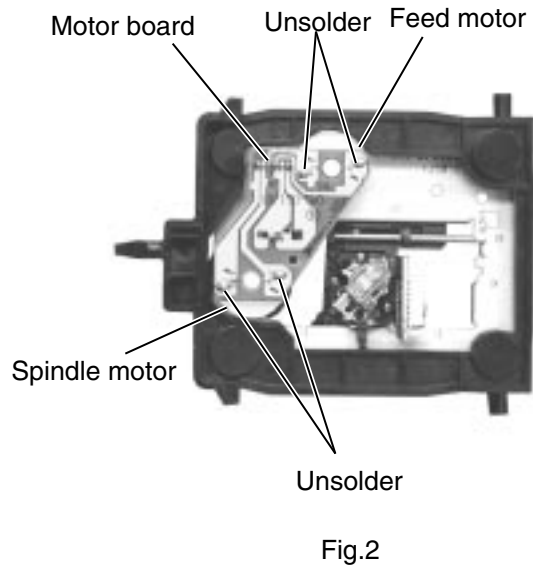



## <Cassette mechanism section>

- Removing the record/playback mechanism.

### ■ Removing the R/P head.

1. Remove the screw **A** on the right side of the R/P head.(Fig.1, Fig.2)
2. Remove the screw **B** on the left side of the R/P head.(Fig.1, Fig.2)

### ■ Remove the erase head.

Remove the screw **C** fixing the erase head.(Fig.1)

### ■ Removing the pinch roller.

1. Pull out the pinch roller by opening the pinch roller stopper outward to unlock .(Fig.3)
2. When reassembling the pinch roller, refer to fig. 4 to hook up the spring.

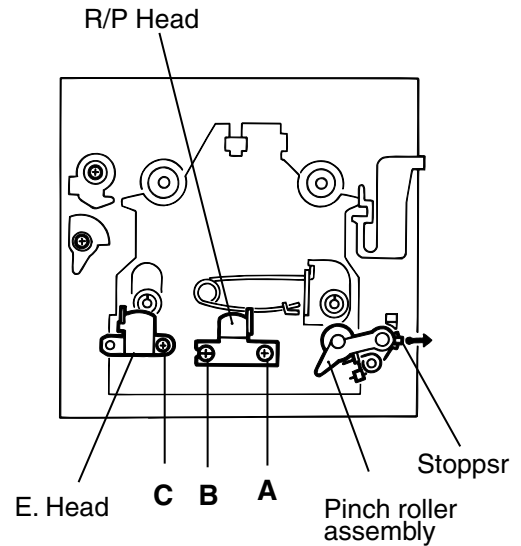

Fig.1

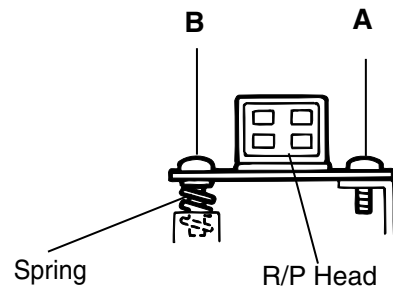

Fig.2

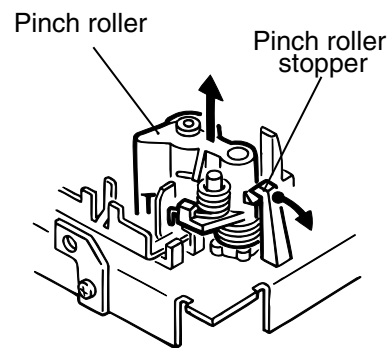

Fig.3

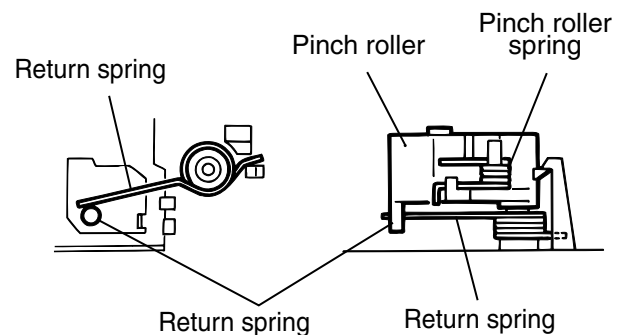

Fig.4

■ **Removing the motor.**

1. Remove the two screws **D** fixing the motor.  
Be careful to grease's splash when the drive belt comes off.(Fig.5, Fig.6)
2. Unsolder the motor terminal.(Fig.5)

■ **Removing the mechanism board.**

1. Unsolder the four parts **a** on the solenoid coil terminal.(Fig.5)
2. Remove the two screws **E** fixing the board.(Fig.5)
3. Unhook the three parts **b** from the board.(Fig.5)
4. Remove the mechanism board.(Fig.5)

■ **Removing the flywheel.**

Remove the cut-washers at **c** and **d** from the capstan shaft, then remove the flywheel.  
When reassembling the flywheel, be sure to use new washers as they cannot be reused.(Fig.8, Fig.9)

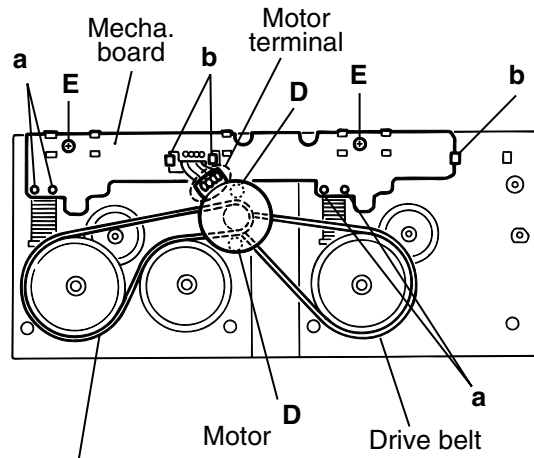

Fig.5

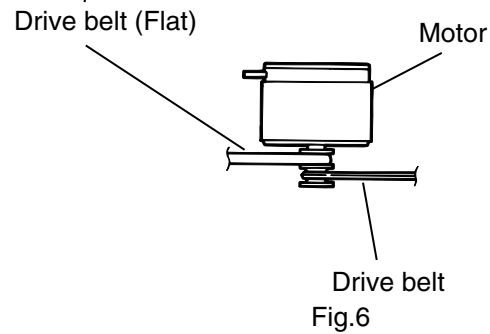

Fig.6

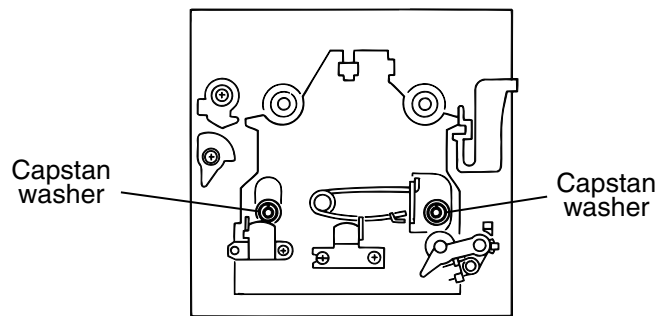

Fig.7

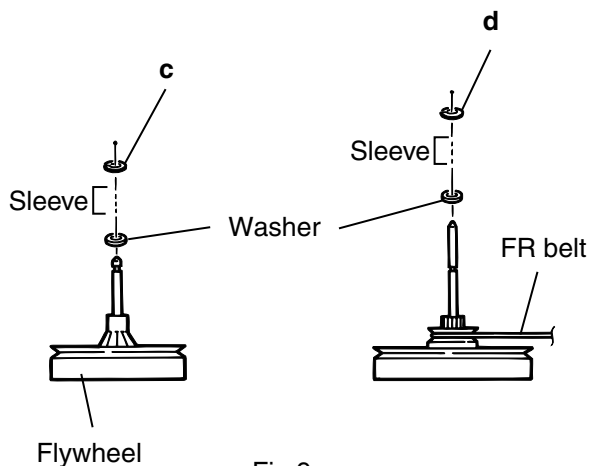

Fig.9

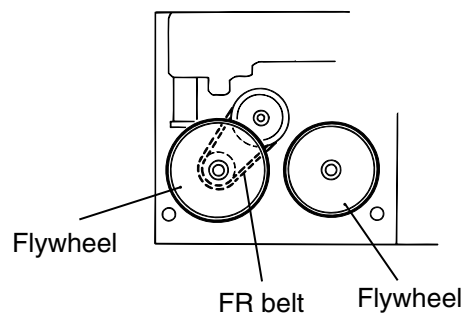
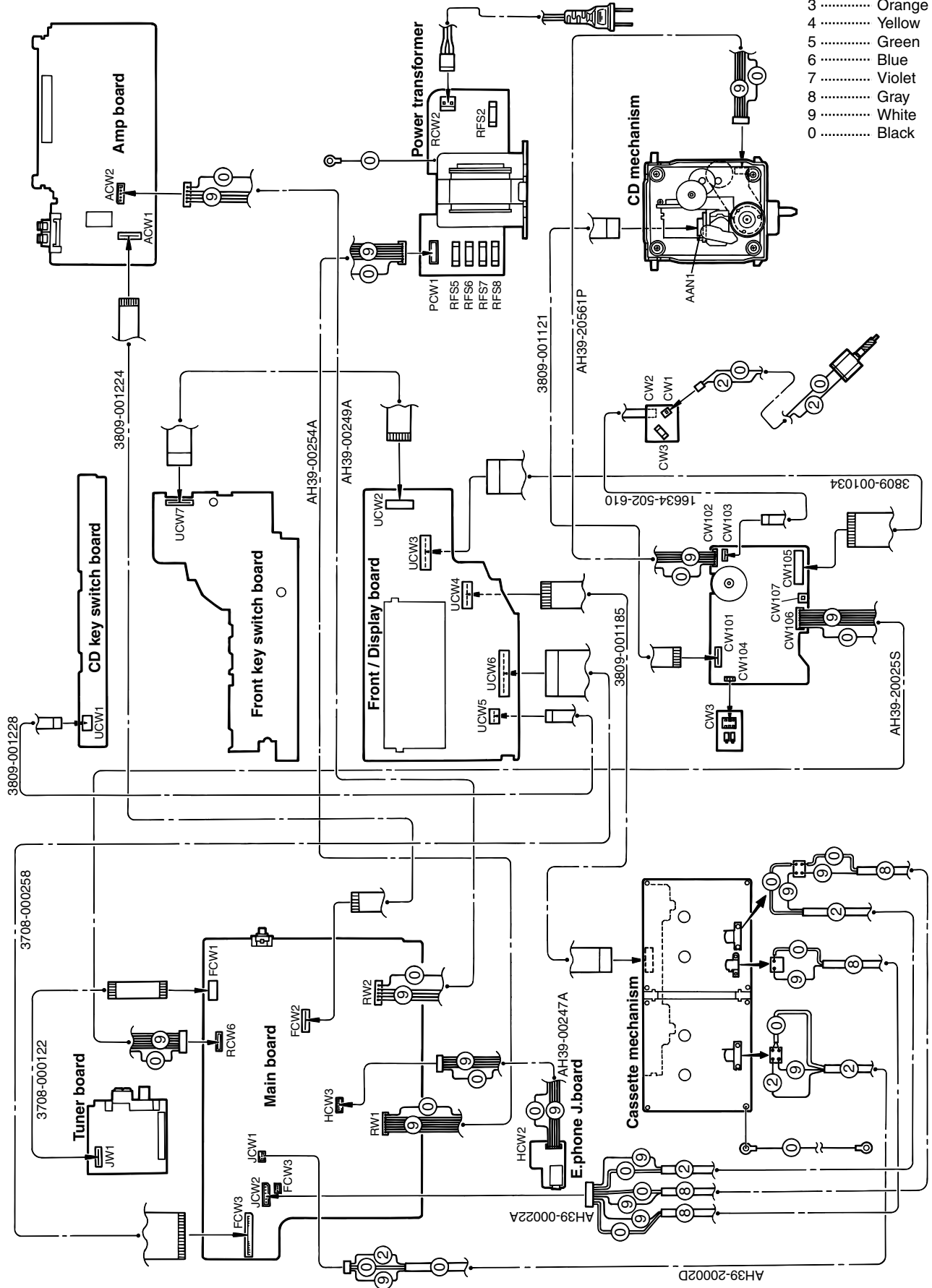

Fig.8

# Wiring connection

Color codes are shown below.

- 1 ..... Brown
- 2 ..... Red
- 3 ..... Orange
- 4 ..... Yellow
- 5 ..... Green
- 6 ..... Blue
- 7 ..... Violet
- 8 ..... Gray
- 9 ..... White
- 0 ..... Black



AH39-20002D

# Adjustment method

## 1. Tuner

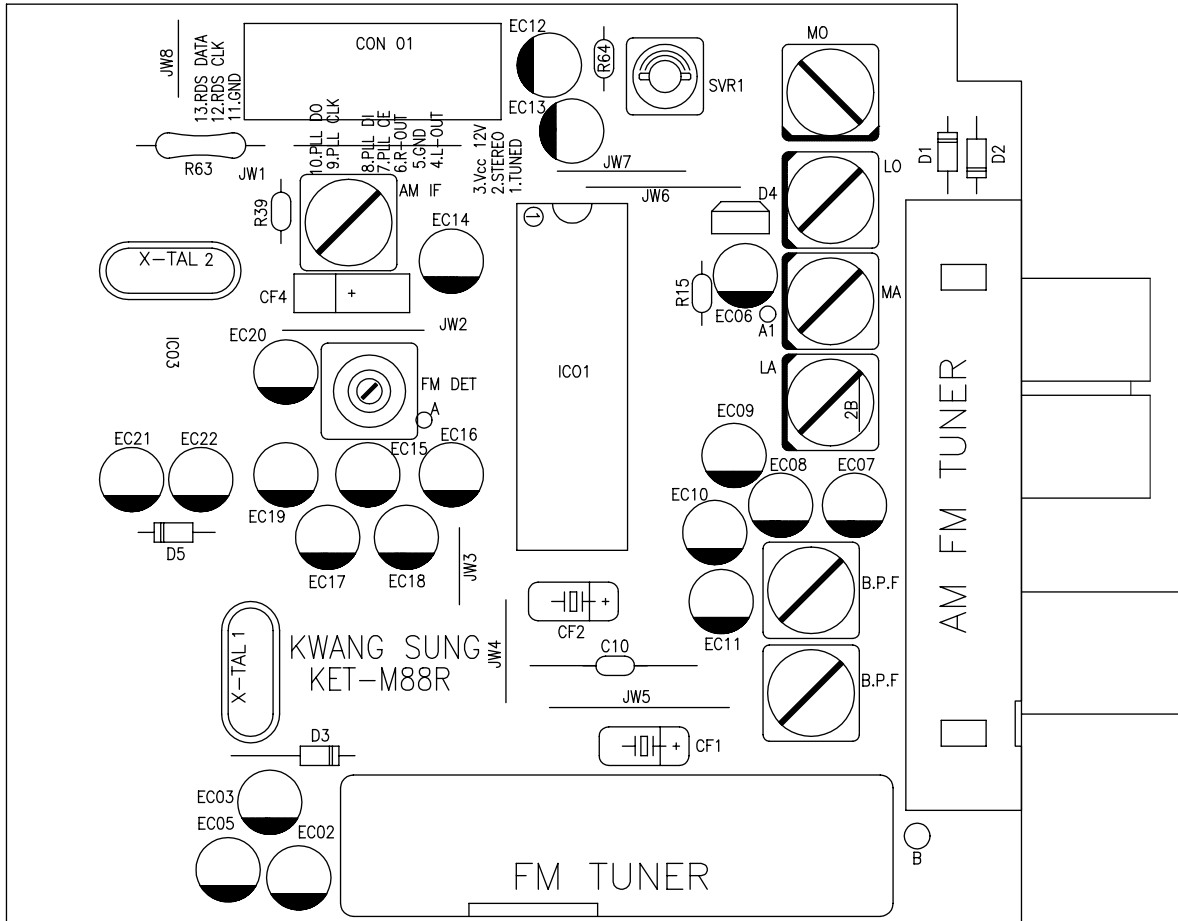

\* Adjustment Location of Tuner PCB

ITEAM	AM(MW) OSC Adjustment	AM(MW) RF Adjustment	LW OSC Adjustment (Except for J/C)	AM(MW) RF Adjustment
Received FREQ.	530~1710 KHz	594 KHz	146~290 KHz	150 KHz
Adjustment point	MO	MA	LO	LA
Output	1~7.0 ± 0.5V	Maximum Output(Fig1-4)	2~7.0 ± 0.5V	Maximum Output(Fig1-4)

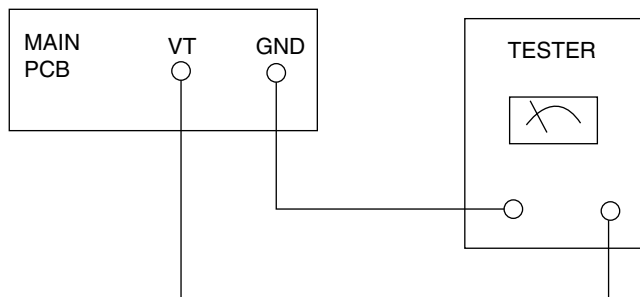

Fig 1-4 OSC Voltage

FM THD Adjustment	
SSG FREQ.	98 MHz
Adjustment point (FM DET)	FM DETECTOR COIL
Output	60 dB
Minimum Distortion (0.4% below) (Figure 1-1)	

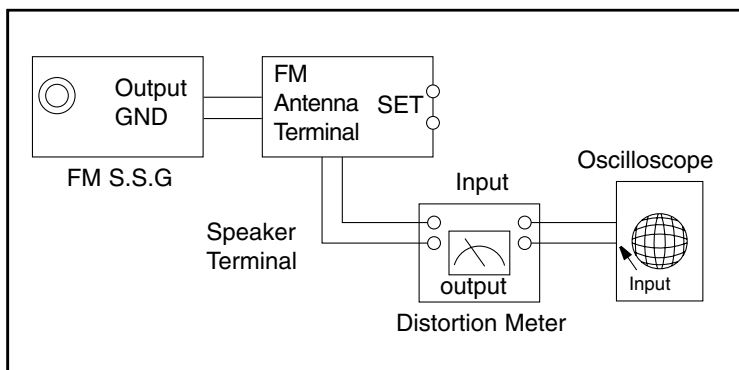

Figure1-1 IF CENTER and THD Adjustment

FM Search Level Adjustment	
SSG FREQ.	98 MHz
Adjustment point (SVR1)	BEACON SENSITIVITY SEMI-VR(20KΩ)
Output	28 dB( ± 2dB)
Adjust SVR1 so that "TUNED" of FL T is lighted (Figure 1-2)	

\*Adjust FM S.S.G level to 28dB

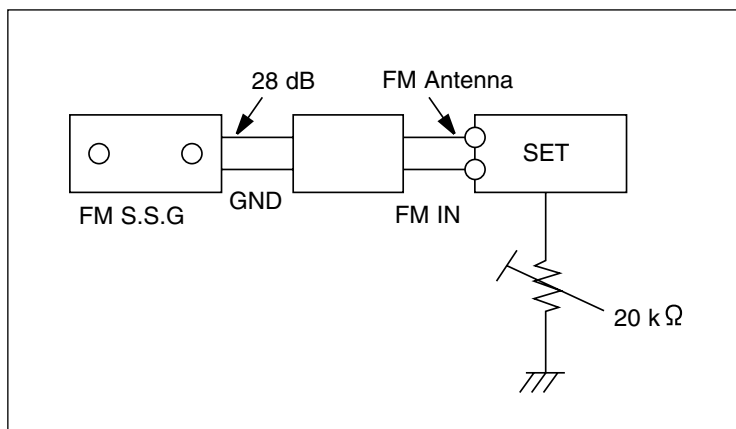

Figure1-2 FM Auto Search Level Adjustment

AM(MW) I.F Adjustment	
SSG FREQ.	450 kHz
Frequency	522 kHz
Adjustment point	AM IF
Maximum output (Figure 1-3)	

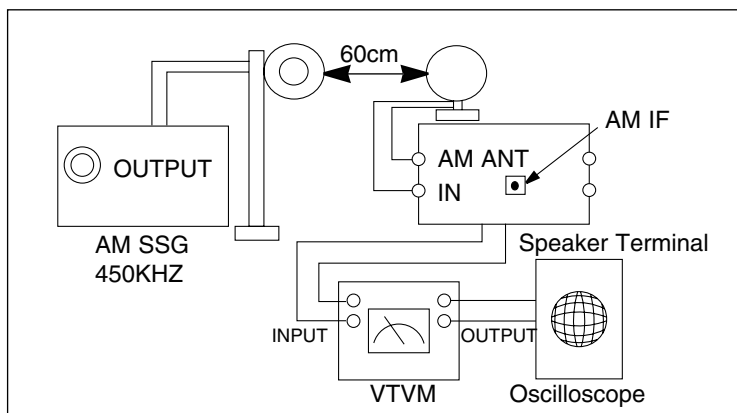

Figure1-3 AM I.F Adjustment

## 2 Cassette Deck

### To adjust tape speed

Notes

- 1) Measuring tape: i) VT-712/MTT-111(or equivalent)  
(Tapes recorded with 3kHz)  
ii) AC-225/MTT-5512(or equivalent)
- 2) Connect the cassette deck to the frequency counter as in figure 1-5.

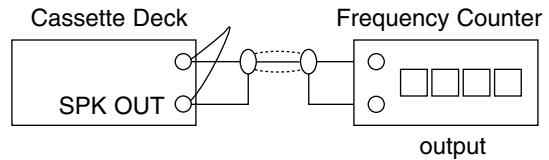
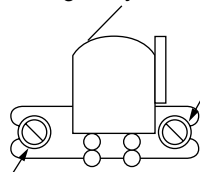

Figure 1-5

Step	Item	Pre-Setup Condition	Pre-Setup	To Adjust	Standard	Remark
1	NOR SPEED Control	OUT (connected to the frequency counter)	1) Deck 1:VT-712 2) Press PLAY SW button 3) Deck 2:Same as above	Turn VSR1 to left and right (FRONT PCB)	3KHz	$\pm 1\%$ range

Recording /Play head



AZIMUTH control screw

Figure 1-6

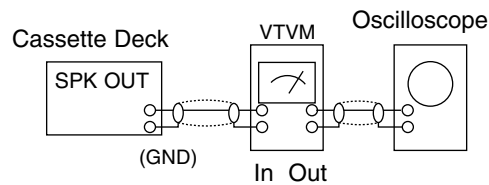

Figure 1-7

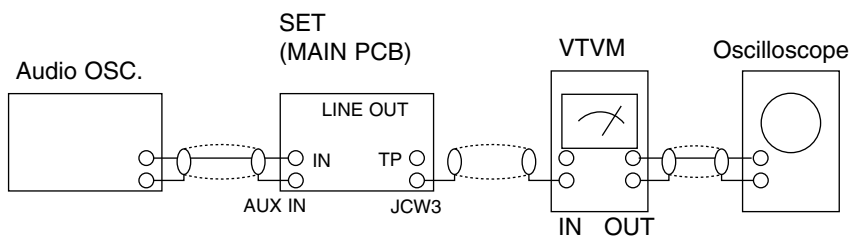

Figure 1-8

**To adjust playback level/REC**

-114N(or equivalent 10kHz AZIMUTH control)

## Notes

- 1) Before the actual adjustment, clean the play/recording head.
- 2) Measuring tape :
  - i) VT-703 / MTT-114N(or equivalent 10kHz AZIMUTH control)
  - ii) AC-225/MTT-5512(or equivalent)
- 3) The cassette deck is connections as shown in figure 1-7.

**1. Adjust Deck 1 Play Level**

Step	Item	Pre-Setup Condition	Pre-Setup	To Adjust	Standard	Remark
1	AZIMUTH	SPK OUT (VTVM is connected to the scope)	After putting MTT-114N into Deck 1 - Press FWD PLAY button.	- Turn the control screw to as shown in Figure 1-6.	Max output and same phase (both channels)	After adjustment secure it with REGION LOCK.

**2. Adjust Deck 2 Play Level/REC BIAS**

Step	Item	Pre-Setup Condition	Pre-Setup	To Adjust	Standard	Remark
1	AZIMUTH	SPK OUT (VTVM is connected to the scope)	After putting VT-703 into Deck 2 1) Press FWD PLAY button.	- Turn the control screw to as shown in Figure 1-6.	Max output and same phase (both channels)	After adjustment secure it with REGION LOCK.
2	Recording Bias Voltage	Fig 1-8	After putting AC-225 into Deck 2 1) Press REC PLAY button. 2) MAIN PCB JCW3, connected to VTVM	Turn JSR2L, JSR2R to the right and left	7mV( $\pm 0.5$ mV)	

# Flow of functional operation until TOC read

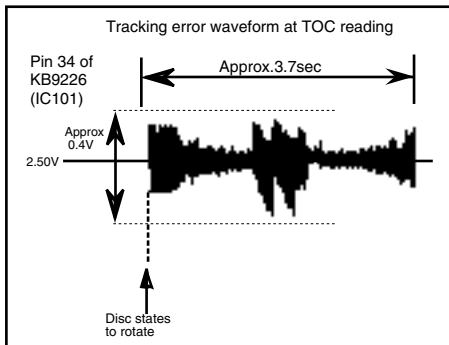
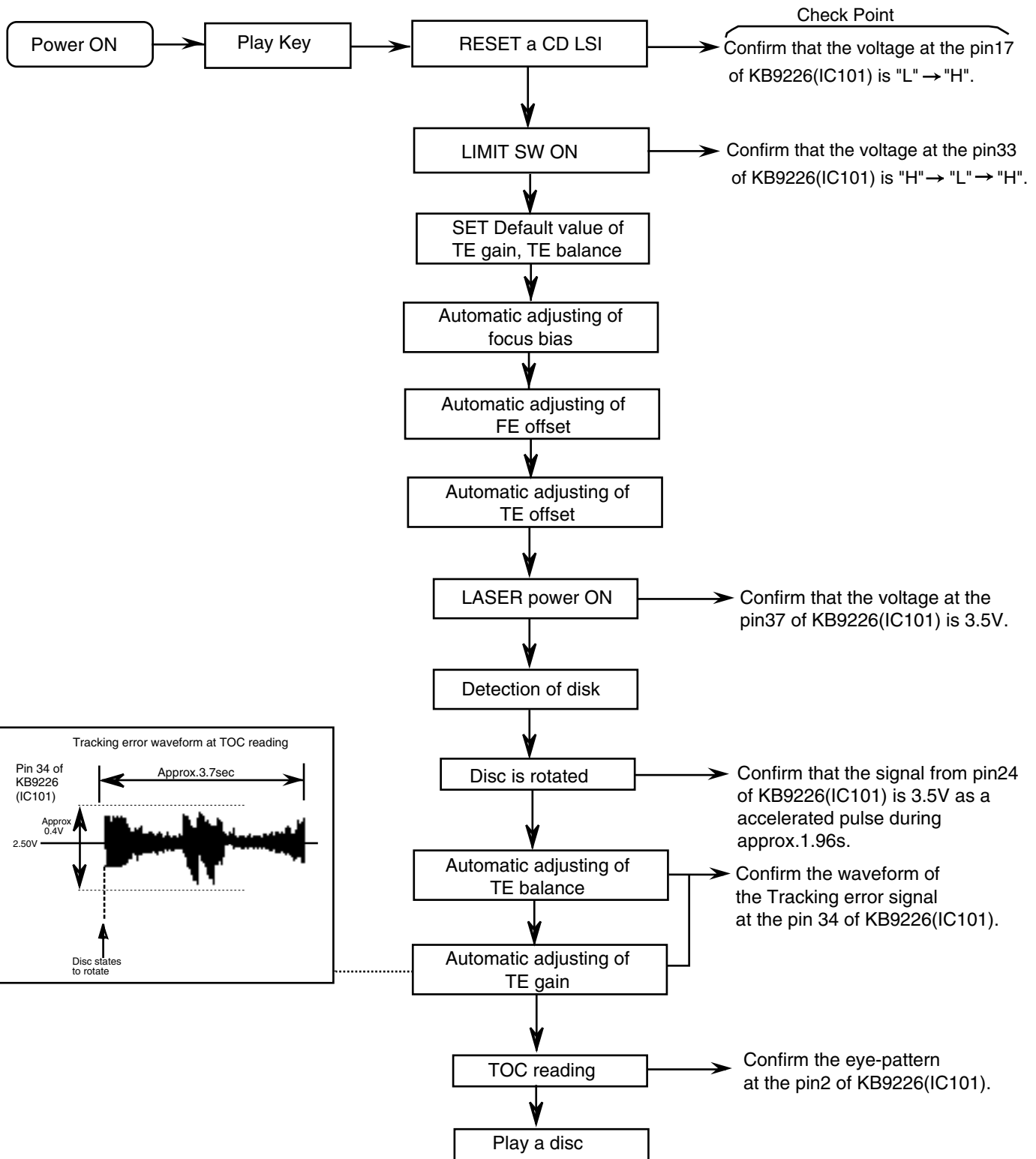



## Maintenance of laser pickup

- (1) Cleaning the pick up lens  
Before you replace the pick up, please try to clean the lens with a alcohol soaked cotton swab.
- (2) Life of the laser diode  
When the life of the laser diode has expired, the following symptoms will appear.
  1. The level of RF output (EFM output: amplitude of eye pattern) will below.

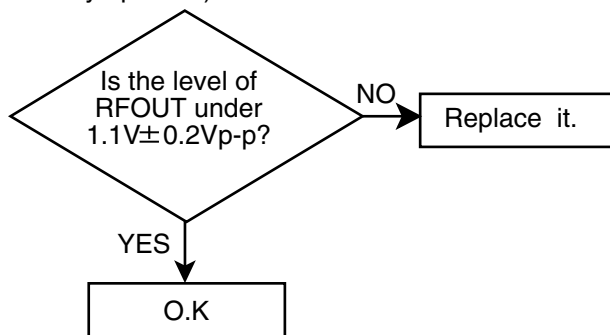

## Replacement of laser pickup

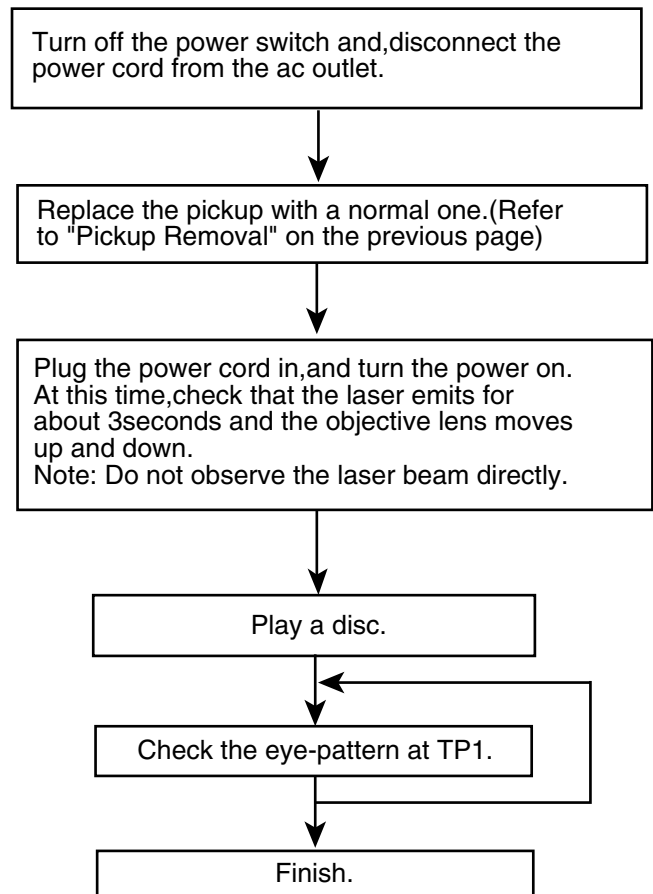

### (3) Semi-fixed resistor on the APC PC board

The semi-fixed resistor on the APC printed circuit board which is attached to the pickup is used to adjust the laser power. Since this adjustment should be performed to match the characteristics of the whole optical block, do not touch the semi-fixed resistor.

If the laser power is lower than the specified value,the laser diode is almost worn out, and the laser pickup should be replaced.

If the semi-fixed resistor is adjusted while the pickup is functioning normally,the laser pickup may be damaged due to excessive current.

# Troubleshooting

## 1. Amplifier

### Power malfunction

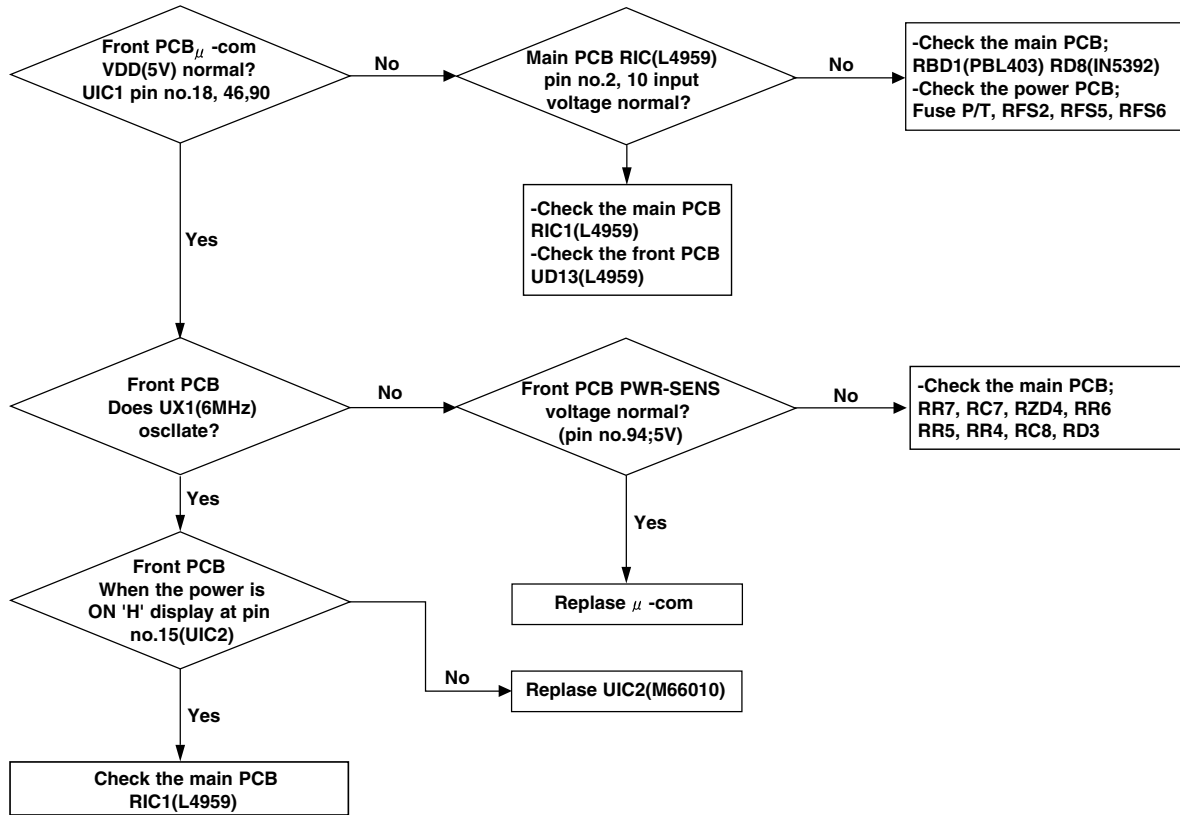

### No output

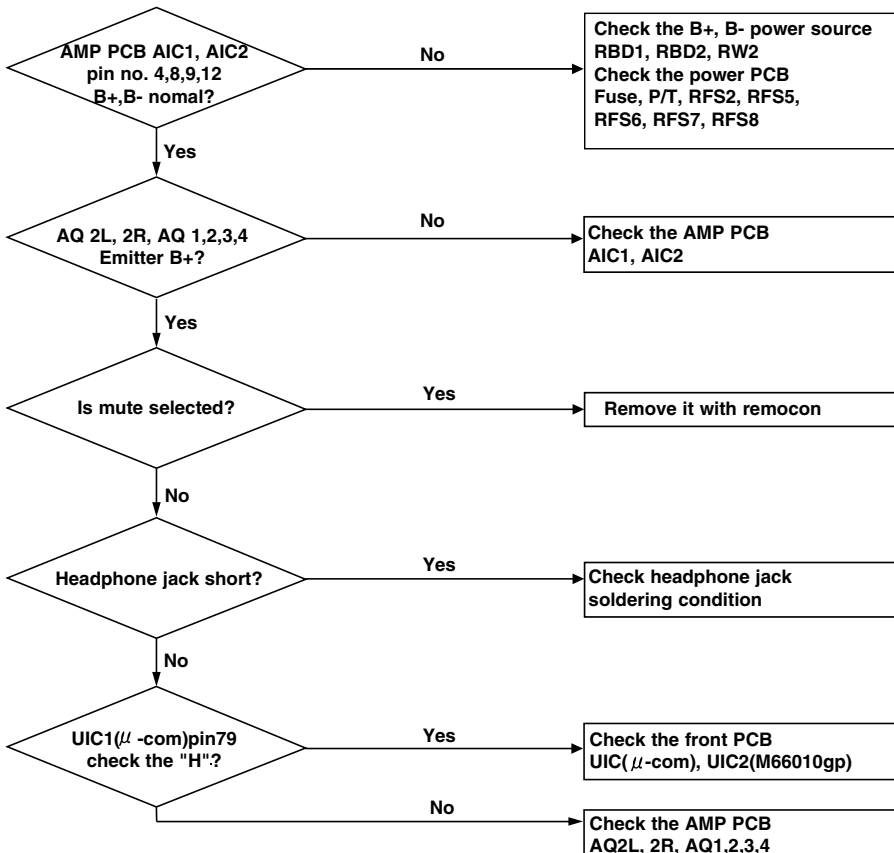

## 2. Tuner malfunction(FM/AM)

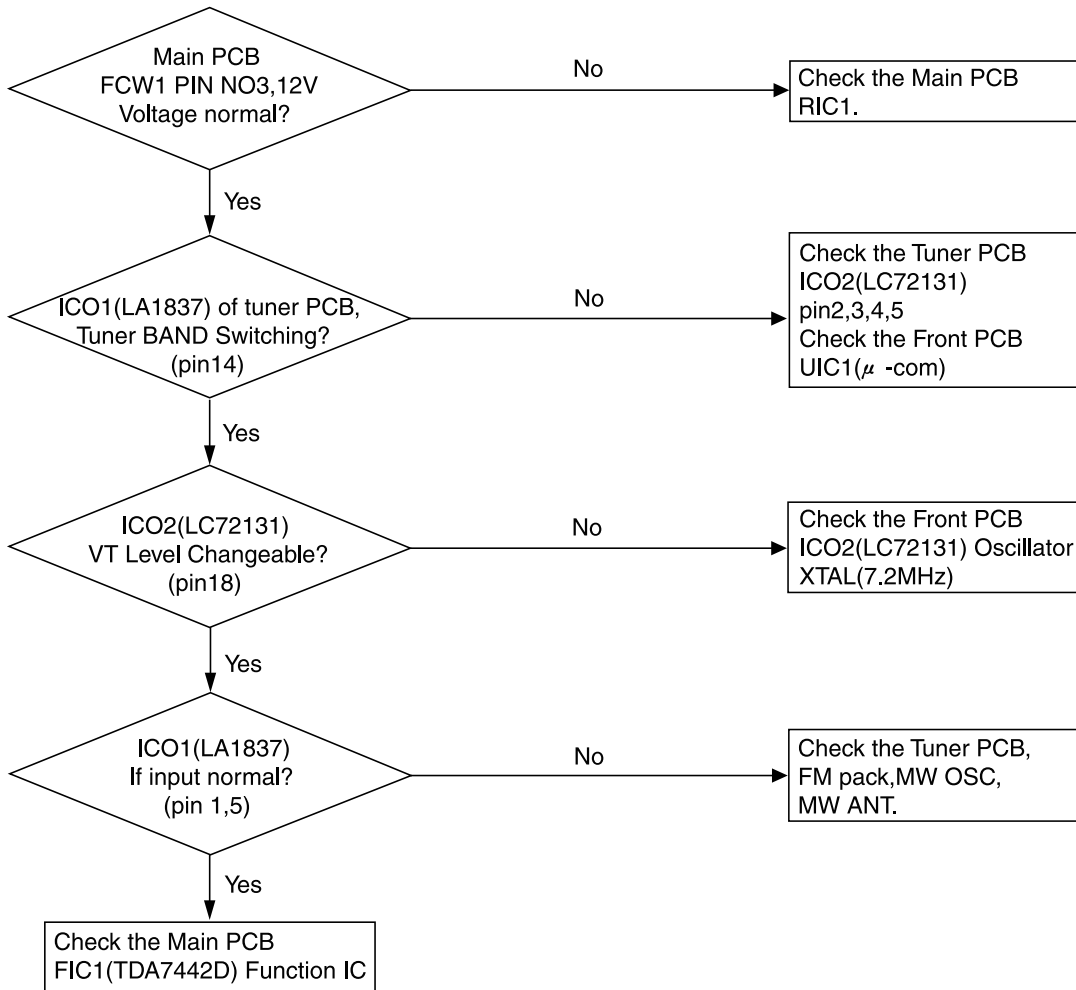

## 3. Tape malfunction

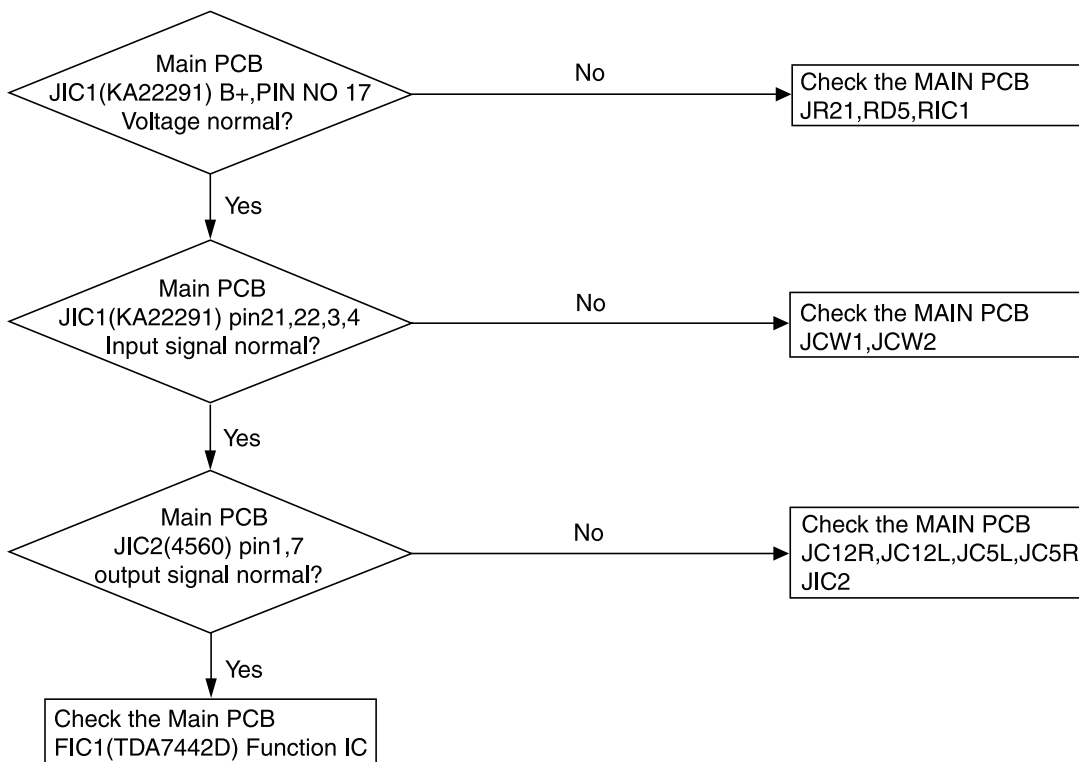

4. CD

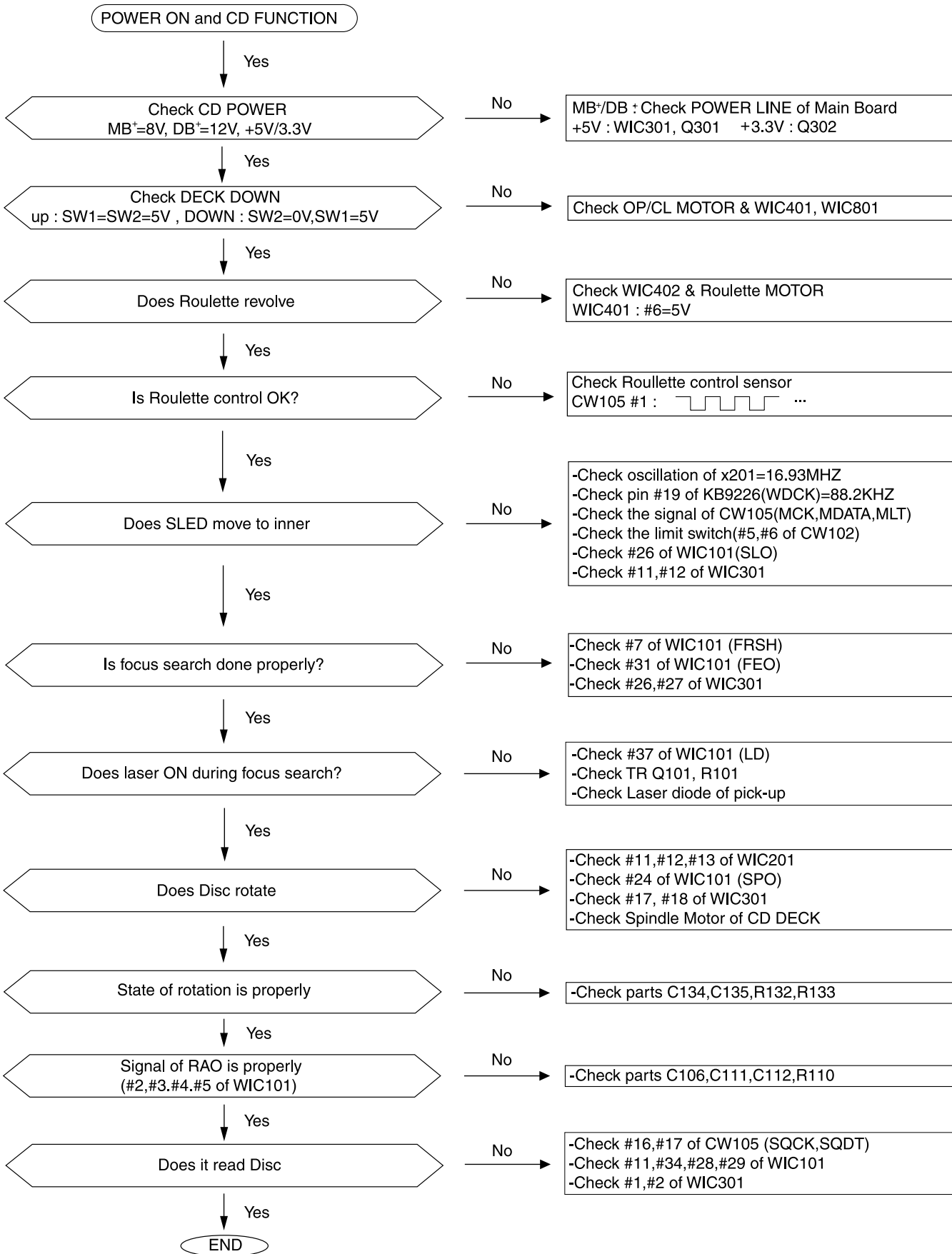

# Description of major ICs

## ■ L4959 (RIC1) : Voltage regulator

### 1.Pin layout

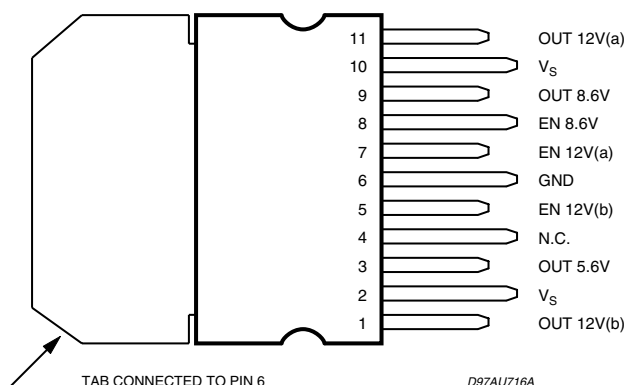

### 2.Block diagram

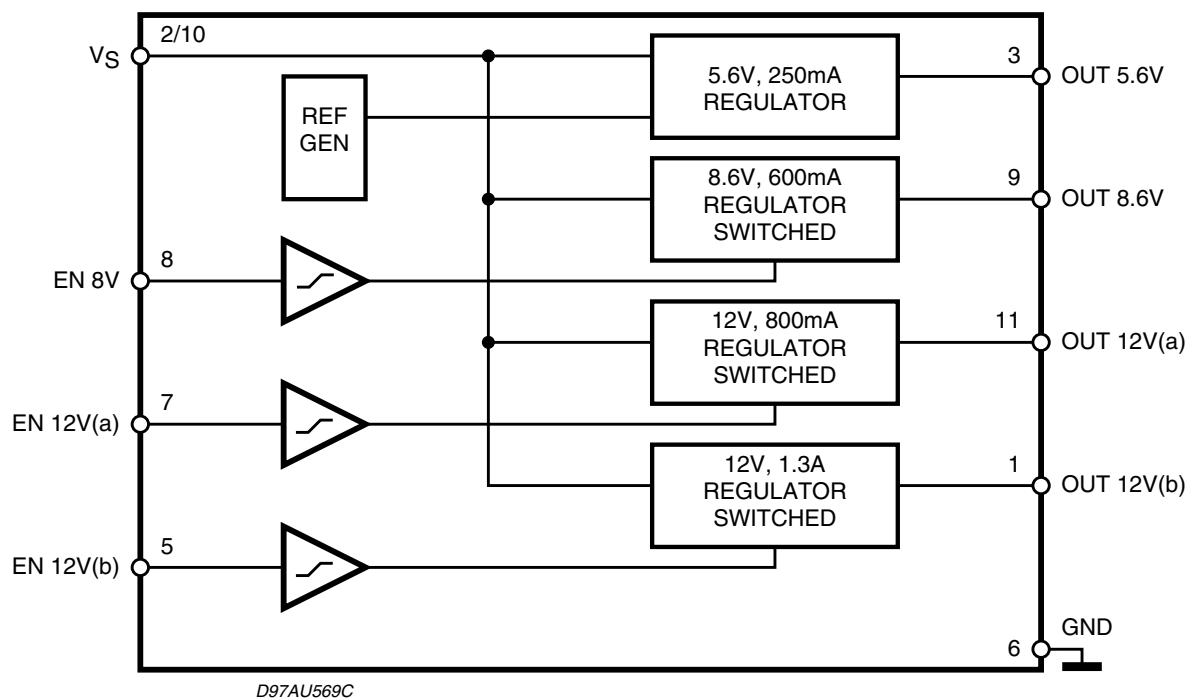

### 3.Pin function

Pin	Pins	Description
1	OUT 12V (b)	12V/1.3A SWITCHED OUTPUT VOLTAGE
2	V <sub>s</sub>	Supply Voltage
3	OUT 5.6V	5.6V/250mA OUTPUT VOLTAGE
4	N.C.	not connected
5	EN 12V (b)	Enable 12V/1.3A SWITCHED OUTPUT VOLTAGE
6	GND	Ground
7	EN 12V (a)	Enable 12V/0.8A SWITCHED OUTPUT VOLTAGE
8	EN 8.6V	Enable 8.6V/0.6A SWITCHED OUTPUT VOLTAGE
9	OUT 8.6	8.6V/0.6A SWITCHED OUTPUT VOLTAGE
10	V <sub>s</sub>	Supply Voltage
11	OUT 12V (a)	12V/0.8A SWITCHED OUTPUT VOLTAGE

■ 5L9290 (IC201) : DIGITAL SIGNAL PROCESSOR FOR CDP

1. Pin layout

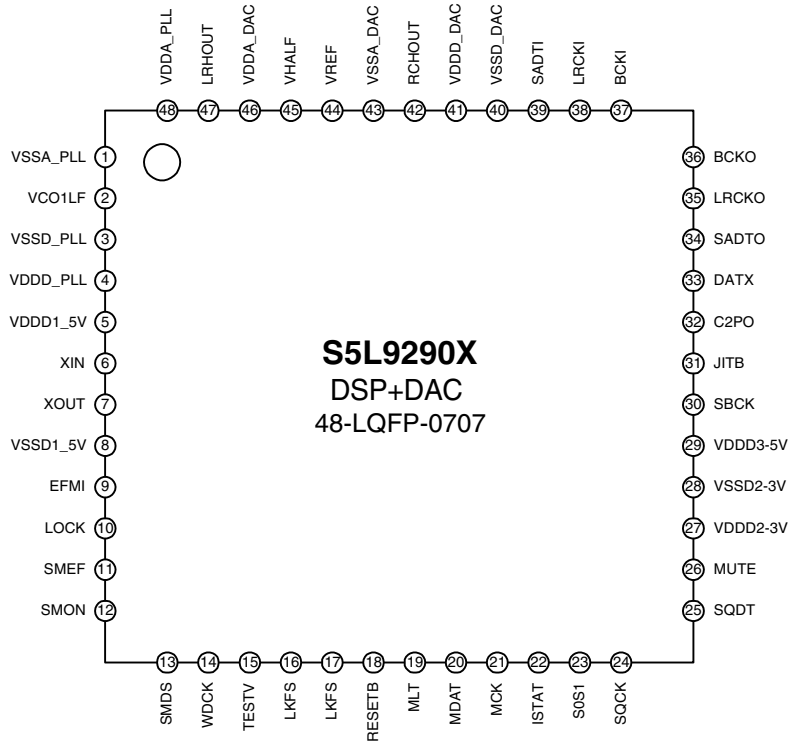

2. BLOCK DIAGRAM

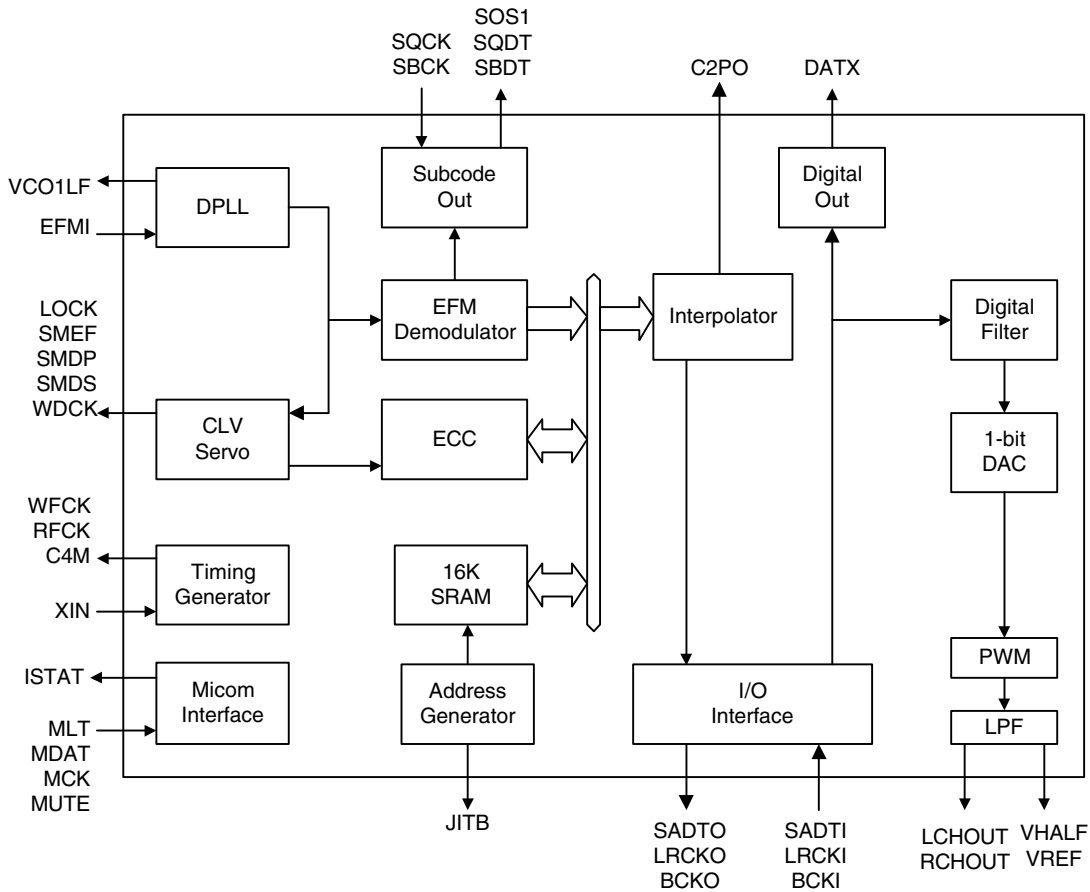

## 3. Pin function

(1/2)

NO.	NAME	I/O	Pin Description
1	VSSA_PLL	-	Analog Ground for DPLL
2	VCO1LF	O	Pump out for VCO1
3	VSSD_PLL	-	Digital Ground Separated Bulk Bias for DPLL
4	VDDD_PLL	-	Digital Power Separated Bulk Bias for DPLL (3V Power)
5	VDDD1-5V	-	Digital Power (5V Power, I/O PAD)
6	XIN	I	X'tal oscillator input (16.9344MHz)
7	XOUT	O	X'tal oscillator output
8	VSSD1	-	Digital Ground (I/O PAD)
9	EFMI	I	EFM signal input
10	LOCK	O	CLV Servo locking status output
11	SMEF	O	LPF time constant control of the spindle servo error signal
12	SMDP	O	Phase control output for Spindle Motor drive
13	SMDS	O	Speed control output for Spindle Motor drive
14	WDCK	O	Word clock output (Normal Speed : 88.2KHz, Double Speed : 176.4KHz)
15	TESTV	I	Various Data/Clock Input
16	LKFS	O	The Lock status output of frame sync
17	C4M	O	4.2336MHz clock output
18	RESETB	I	System Reset at 'L'
19	MLT	I	Latch signal input from Micom
20	MDAT	I	Serial data input from Micom
21	MCK	I	Serial data receiving clock input from Micom
22	ISTAT	O	The internal status output to Micom
23	S0S1	O	Subcode sync signal(S0+S1) output
24	SQCK	I	Subcode-Q data transferring bit clock input

## 3. Pin function

(2/2)

NO.	NAME	I/O	Function Description
25	SQDT	O	Subcode-Q data serial output
26	MUTE	I	System mute at 'H'
27	VDDD2-3V	-	Digital Power (3V Power, Internal Logic)
28	VSSD2	-	Digital Ground (Internal Logic)
28	VDDD3-5V	-	Digital Power (5V Power, I/O PAD)
30	SBCK	I	Subcode data transferring bit clock
31	JITB	O	Internal SRAM jitter margin status output
32	C2PO	O	C2 pointer output
33	DATX	O	Digital audio data output
34	SADTO	O	Serial audio data output (48 slot, MSB first)
35	LRCKO	O	Channel clock output
36	BCKO	O	Bit clock output
37	BCKI	I	Bit clock input
38	LRCKI	I	Channel clock input
39	SADTI	I	Serial audio data input (48 slot, MSB first)
40	VSSD_DAC	-	Digital Ground for DAC
41	VDDD_DAC	-	Digital Power for DAC (3V Power)
42	RCHOUT	O	Right-Channel audio output through DAC
43	VSSA_DAC	-	Analog Ground for DAC
44	VREF	O	Reference Voltage output for bypass
45	VHALF	O	Reference Voltage output for bypass
46	VDDA_DAC	-	Analog Power for DAC (3V Power)
47	LCHOUT	O	Left-Channel audio output through DAC
48	VDDA_PLL	-	Analog Power for PLL (3V Power)



■ BA3837

1. Block diagram

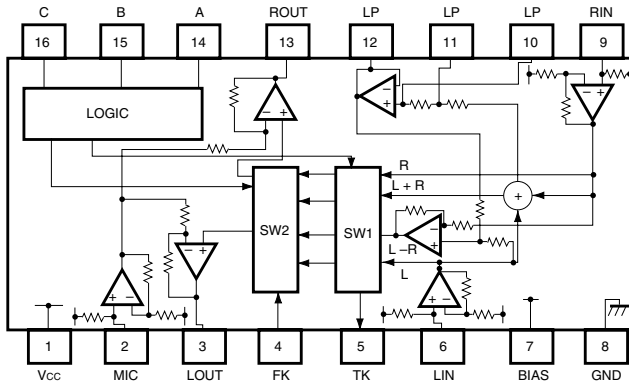

■ BA4560 (AIC3, AIC4, AIC5, AIC6, AIC7, FIC4, HIC1, JIC2) : OP amp.

1. Pin layout

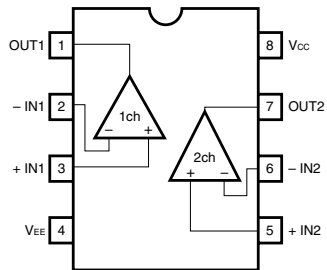

■ KA9258D (IC925) : 4-ch Motor driver

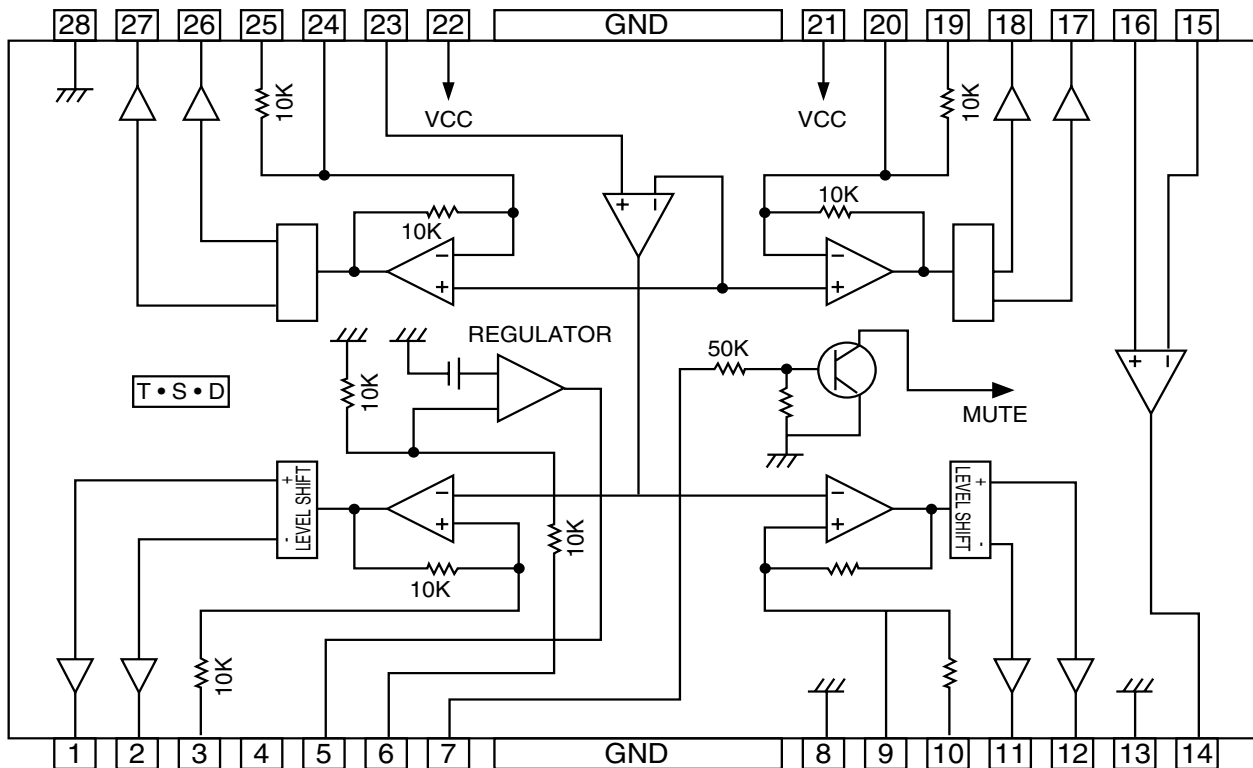

■ KB9226 (IC101) : RF AMP & SERVO SIGNAL PROCESSOR

1. Pin layout

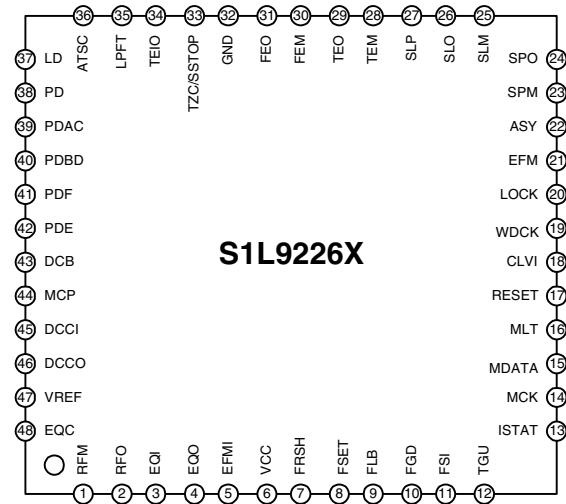

2. BLOCK DIAGRAM

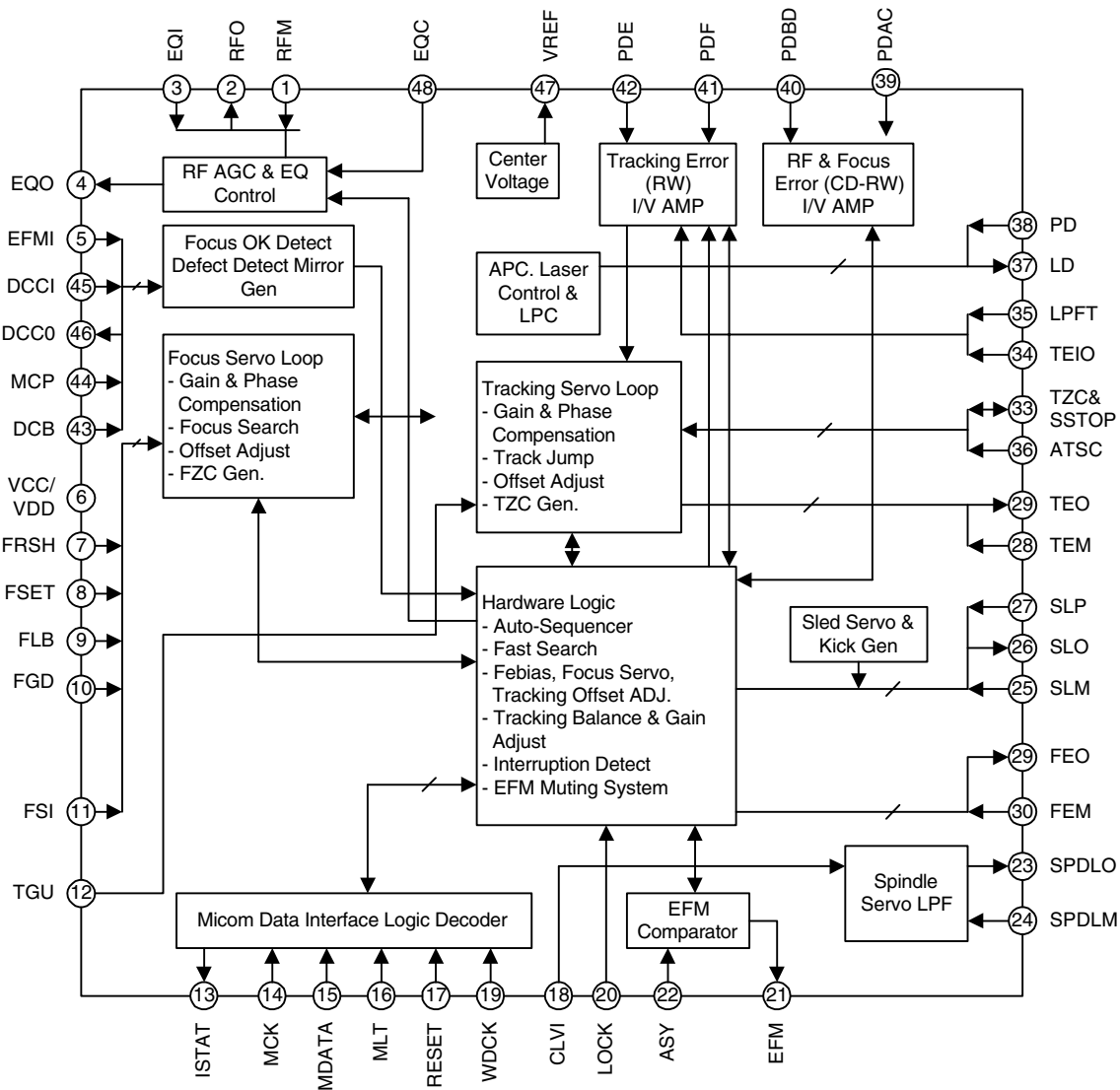

## 3. Pin function

(1/2)

Pin No.	Symbol	I/O	Description
1	RFM	I	RF summing amp. inverting input
2	RFO	O	RF summing amp. output
3	EQI	I	RFO DC eliminating input(use by MIRROR, FOK ,AGC & EQ terminal)
4	EQO	O	RF equalizer output
5	EFMI	I	EFM slice input. (input impedance 47K)
6	VCC	P	Main power supply
7	FRSH	I	Capcitor connection to focus search
8	FSET	I	Filter bias for focus,tracking,spindle
9	FLB	I	Capacitor connection to make focus loop rising band
10	FGD	I	Terminal to change the high frequency gain of focus loop
11	FSI	I	Focus servo input
12	TGU	I	Connect the component to change the high frequency of tracking Loop
13	ISTAT	O	Internal status output
14	MCK	I	Micom clock
15	MDATA	I	Data input
16	MLT	I	Data latch input
17	RESET	I	Reset input
18	CLVI	I	Input the spindle control output from DSP
19	WDCK	I	88.2KHz input terminal from DSP
20	LOCK	I	Sled run away inhibit pin (L: sled off & tracking gain up)
21	EFM	O	EFM output for RFO slice(to DSP)
22	ASY	I	Auto asymmetry control input
23	SPM	I	Spindle amp. inverting input
24	SPO	O	Spindle amp. output
25	SLM	I	Sled servo inverting input
26	SLO	O	Sled servo output
27	SLP	I	Sled servo noninverting input
28	TEM	I	Tracking servo amp.inverting input
29	TEO	O	Tracking servo amp. output
30	FEM	I	Focus servo amp. inverting input
31	FEO	O	Focus servo amp. output pin

## 3. Pin function

(2/2)

Pin No.	Symbol	I/O	Description
32	GND	P	Main ground
33	TZC/ SSTOP	I	Tracking zero crossing input & Check the position of pick-up whether inside or not
34	TEIO	B	Tracking error output & Tracking servo input
35	LPFT	I	Tracking error integration input (to automatic control)
36	ATSC	I	Anti-shock input
37	LD	O	APC amp. output
38	PD	I	APC amp. input
39	PDAC	I	Photo diode A & C RF I/V amp. inverting input
40	PDBD	I	Photo diode B & D RF I/V amp. inverting input
41	PDF	I	Photo diode F & tracking(F) I/V amp. inverting input
42	PDE	I	Photo diode E & tracking(E) I/V amp. inverting input
43	DCB	I	Capacitor connection to limit the defect detection
44	MCP	I	Capacitor connection to mirror hold
45	DCCI	O	Output pin to connect the component for defect detect
46	DCCO	I	Input pin to connect the component for defect detect
47	VREF	O	(VCC+GND)/2 Voltage reference output
48	EQC	I	AGC_equalize level control terminal & capacitor terminal to input in to VCA

### ■ STK402-090 (AIC2)

## 1. Pin layout

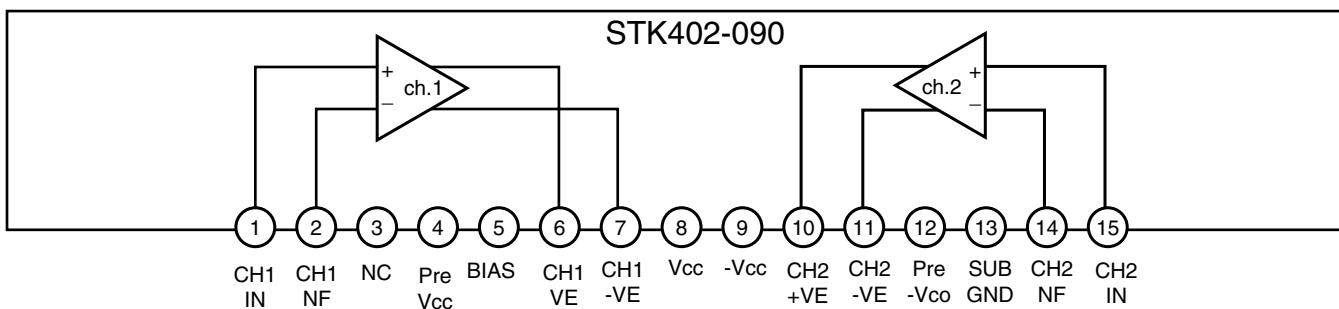

■ KA22291(JIC1) : RB/REC PRE AMP

1.Pin layout

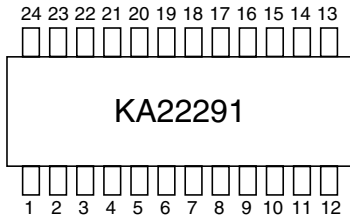

2.Block diagram

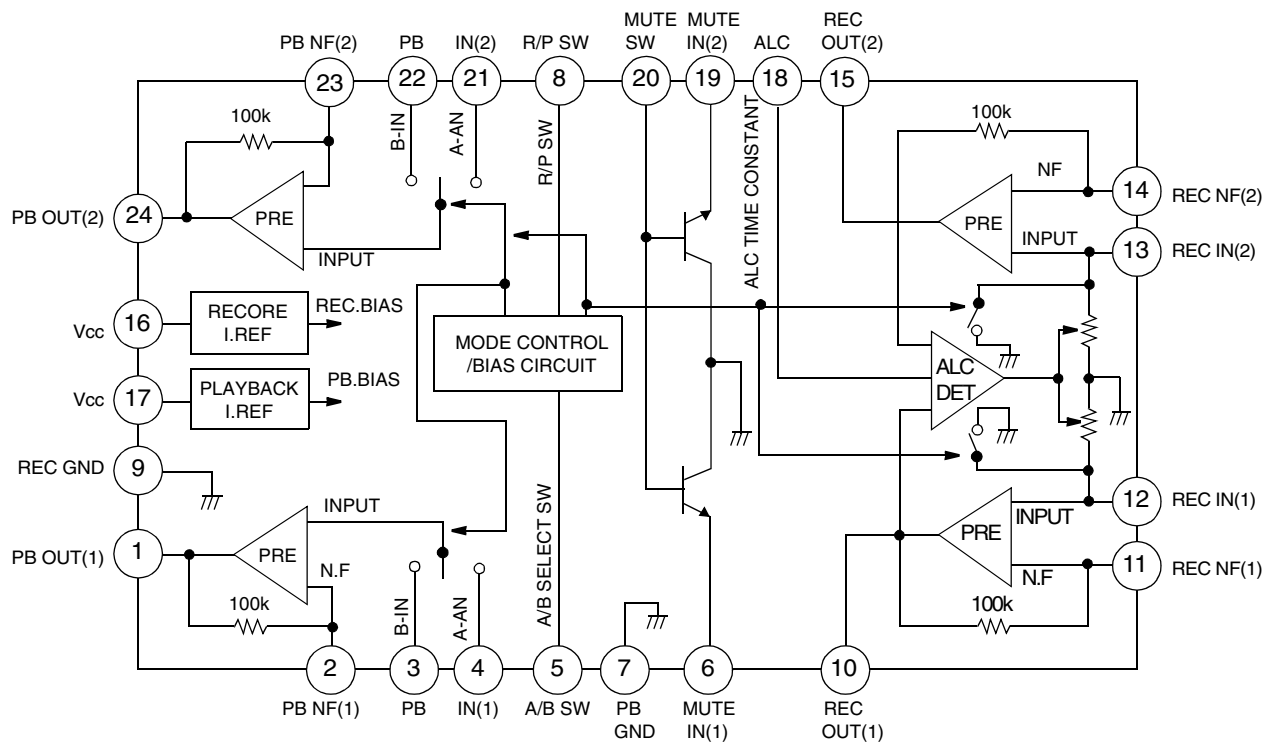

■ LC866548 (UIC1) : Microcontroller

1. Pin layout

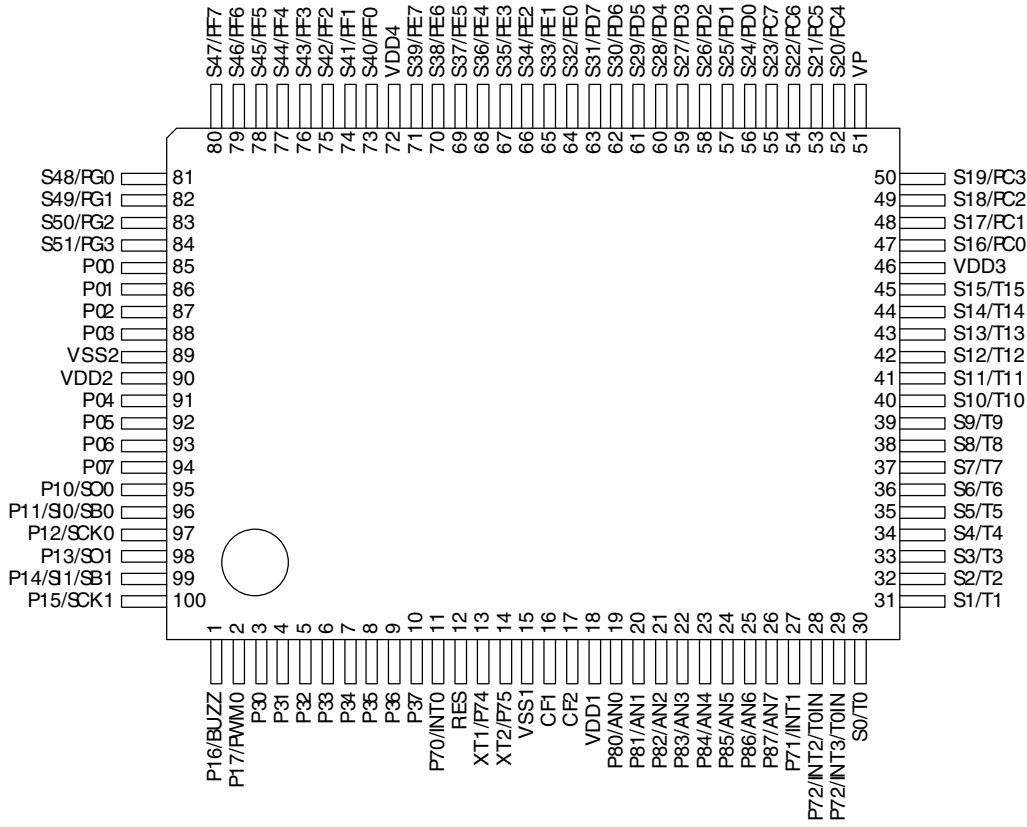

2. Block diagram

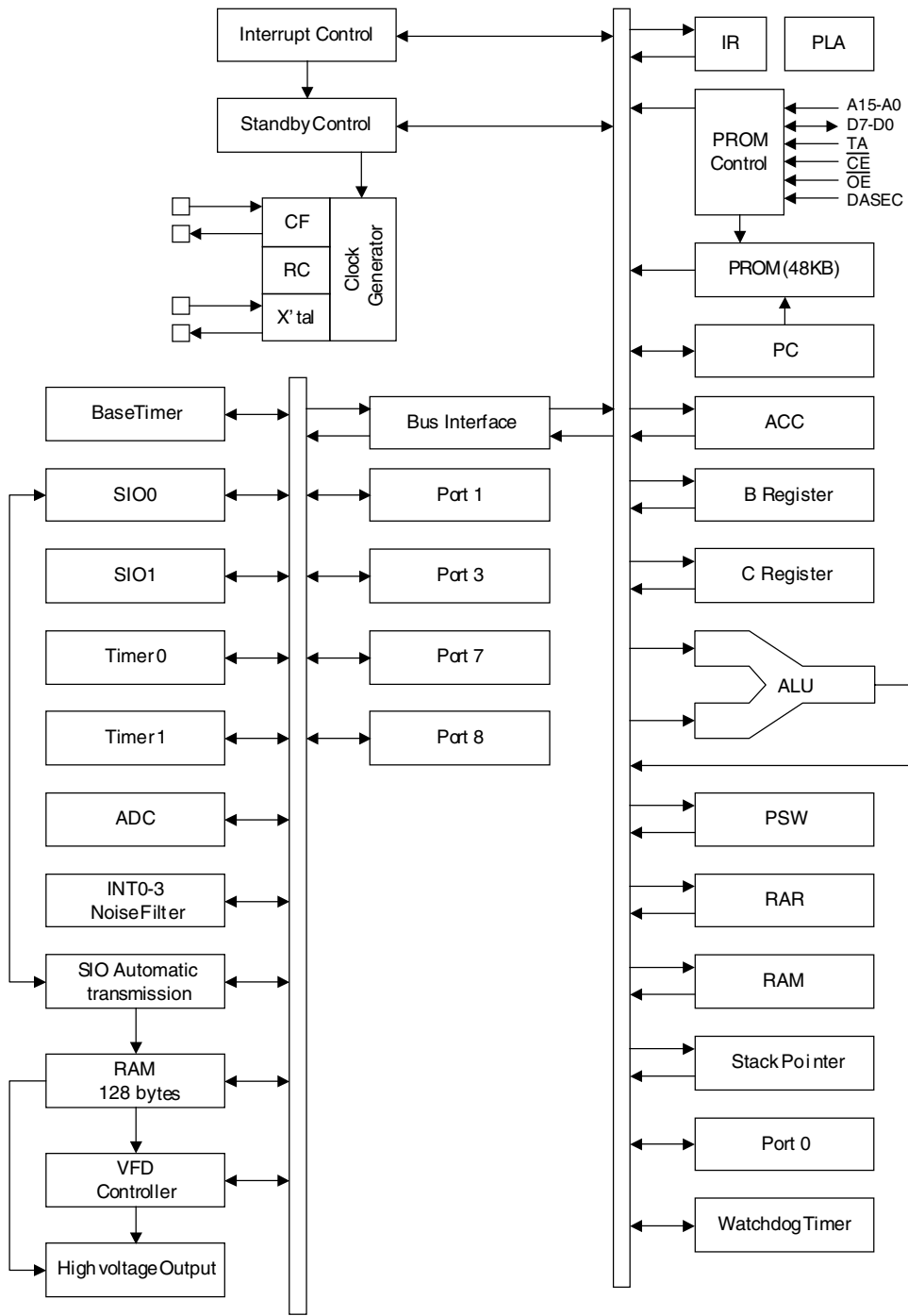

■ M66010 (UIC2) : I/O control

1. Pin layout

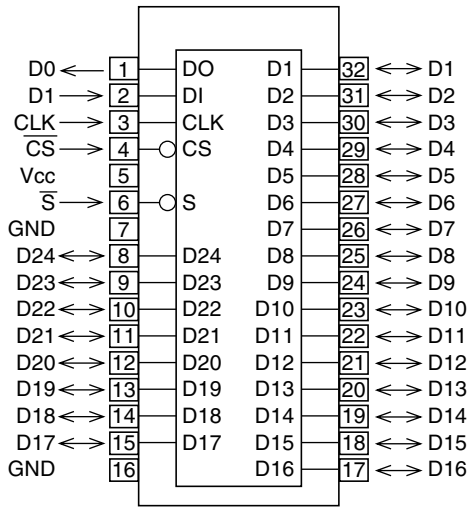

2. Block diagram

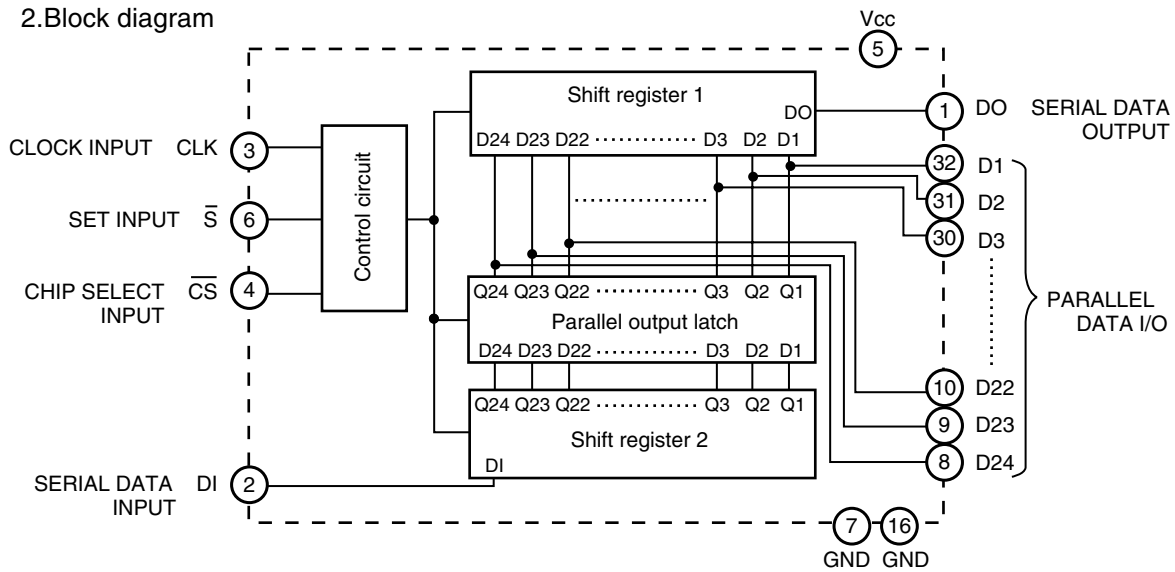



■ TDA7442D (FIC1) : Audio processor

1.Pin layout

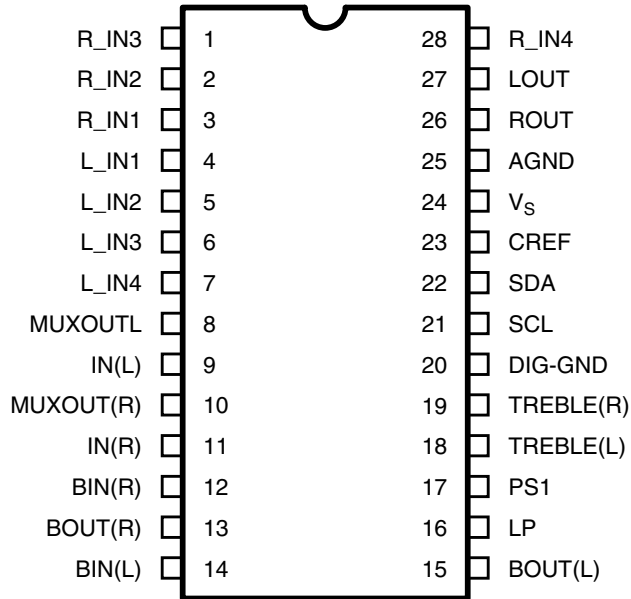

2.Block diagram

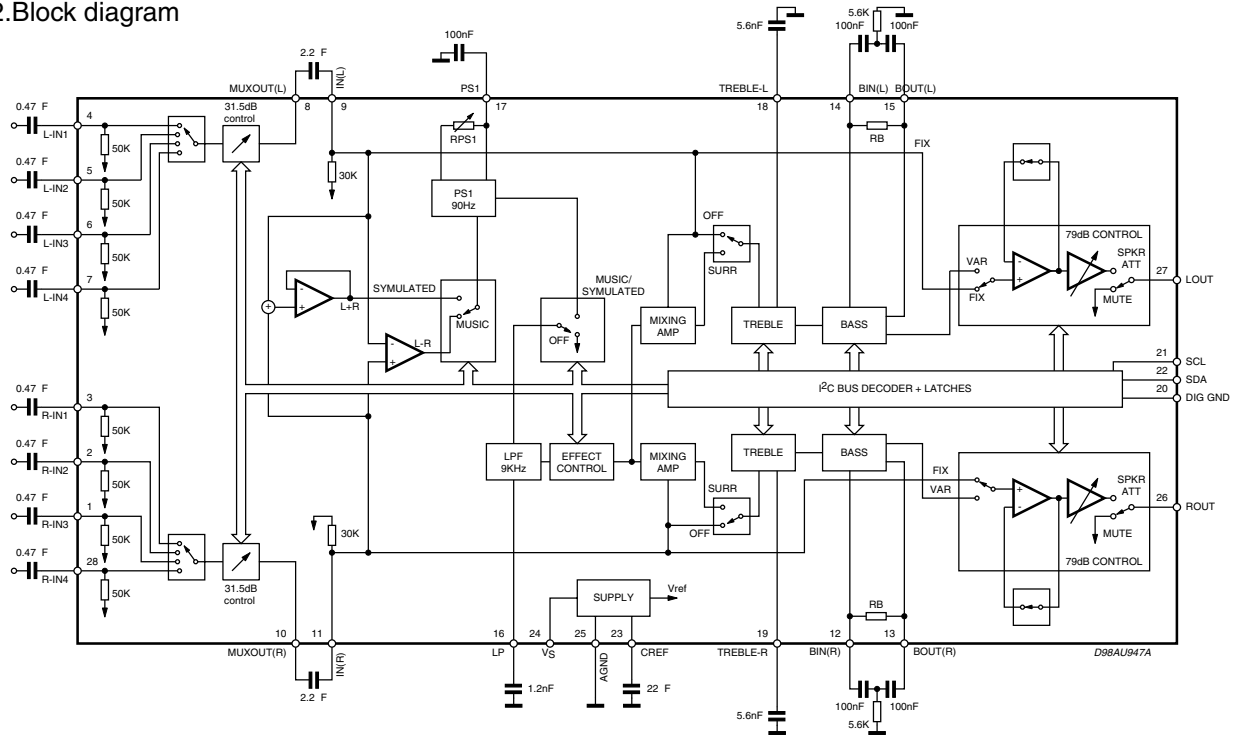

**JVC**

**VICTOR COMPANY OF JAPAN, LIMITED**

AUDIO & COMMUNICATION BUSINESS DIVISION

PERSONAL & MOBILE NETWORK BUSINESS UNIT. 10-1,1chome,Ohwatari-machi,Maebashi-city,371-8543,Japan